



US010145298B2

(12) **United States Patent**
Vengen

(10) **Patent No.:** **US 10,145,298 B2**

(45) **Date of Patent:** ***Dec. 4, 2018**

(54) **GAS FLOW AND ENERGY CONVERSION APPARATUS**

(71) Applicant: **Vengen Technologies LLC**, Oak Ridge, NJ (US)

(72) Inventor: **Joseph Vengen**, Oak Ridge, NJ (US)

(73) Assignee: **Vengen Technologies LLC**, Oak Ridge, NJ (US)

(*) Notice: Subject to any disclaimer, the term of this patent is extended or adjusted under 35 U.S.C. 154(b) by 173 days.

This patent is subject to a terminal disclaimer.

(21) Appl. No.: **15/438,799**

(22) Filed: **Feb. 22, 2017**

(65) **Prior Publication Data**

US 2017/0159557 A1 Jun. 8, 2017

Related U.S. Application Data

(63) Continuation of application No. 14/088,424, filed on Nov. 24, 2013, now Pat. No. 9,587,558.

(51) **Int. Cl.**

F02B 57/08 (2006.01)
F02B 59/00 (2006.01)
F01B 13/06 (2006.01)
F02B 57/04 (2006.01)
F02B 75/02 (2006.01)

(52) **U.S. Cl.**

CPC **F02B 57/08** (2013.01); **F01B 13/068** (2013.01); **F02B 57/04** (2013.01); **F02B 59/00** (2013.01); **F02B 75/02** (2013.01); **F02B 2075/027** (2013.01)

(58) **Field of Classification Search**

CPC F02B 59/00; F02B 57/08
See application file for complete search history.

(56) **References Cited**

U.S. PATENT DOCUMENTS

2,049,780 A 8/1936 Rustemeyer
2,153,727 A * 4/1939 Sklenar F01L 7/00
123/190.4
2,181,705 A * 11/1939 Meyer F02B 57/08
123/190.4
2,203,692 A * 6/1940 Meyer F01B 13/062
123/190.4

(Continued)

FOREIGN PATENT DOCUMENTS

GB 1006303 A * 9/1965 F02B 53/00

Primary Examiner — Patrick Maines

(74) *Attorney, Agent, or Firm* — John M. Hammond;
Patent Innovations LLC

(57) **ABSTRACT**

An internal combustion engine comprising an engine block comprised of a main cavity, an intake plenum, and an exhaust plenum; a crankshaft supported within the main cavity of the engine block; a rotating piston assembly contained within the main cavity of the engine block and comprised of a rotatable cylinder housing having a housing axis of rotation and comprised of a plurality of pistons contained in combustion cylinders; and a rotating valve ring contained within the engine block and surrounding the rotating piston assembly, and comprised of intake ports, ignition energy ports, and exhaust ports corresponding to each of the plurality of combustion cylinders. The rotatable cylinder housing has an axis of rotation that is parallel to and offset from the crankshaft axis of rotation.

15 Claims, 19 Drawing Sheets

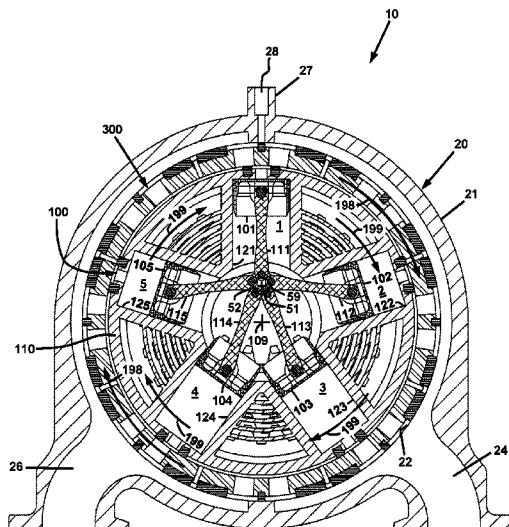

(56)

References Cited

U.S. PATENT DOCUMENTS

2,212,283	A *	8/1940	Weeks	F02B 57/08 123/190.4
2,242,231	A	5/1941	Cantoni	
2,280,669	A *	4/1942	Sklenar	F02B 75/222 123/190.17
3,320,936	A *	5/1967	Phalen	F01C 1/44 123/241
3,739,756	A	6/1973	Villella	
3,991,728	A	11/1976	Vittert	
4,010,719	A	3/1977	Lappa	
4,030,471	A	6/1977	Ginkel	
4,077,365	A	3/1978	Schlueter	
4,078,529	A	3/1978	Warwick	
4,136,646	A	1/1979	Lappa	
4,838,214	A	6/1989	Barrett	
5,682,843	A	11/1997	Clifford	
5,720,241	A	2/1998	Gail	
6,457,443	B1 *	10/2002	Lillbacka	F02B 57/08 123/44 D
6,591,791	B2	7/2003	De Bei	
6,615,793	B1	9/2003	Usack	
6,883,473	B2	4/2005	Wongergem	
6,895,906	B1	5/2005	Gahan	
8,240,147	B2	8/2012	Taba	
2003/0127062	A1	7/2003	Ahn	
2003/0127067	A1	7/2003	Karnes	
2004/0216703	A1 *	11/2004	Wongergem	F01B 13/02 123/44 D

* cited by examiner

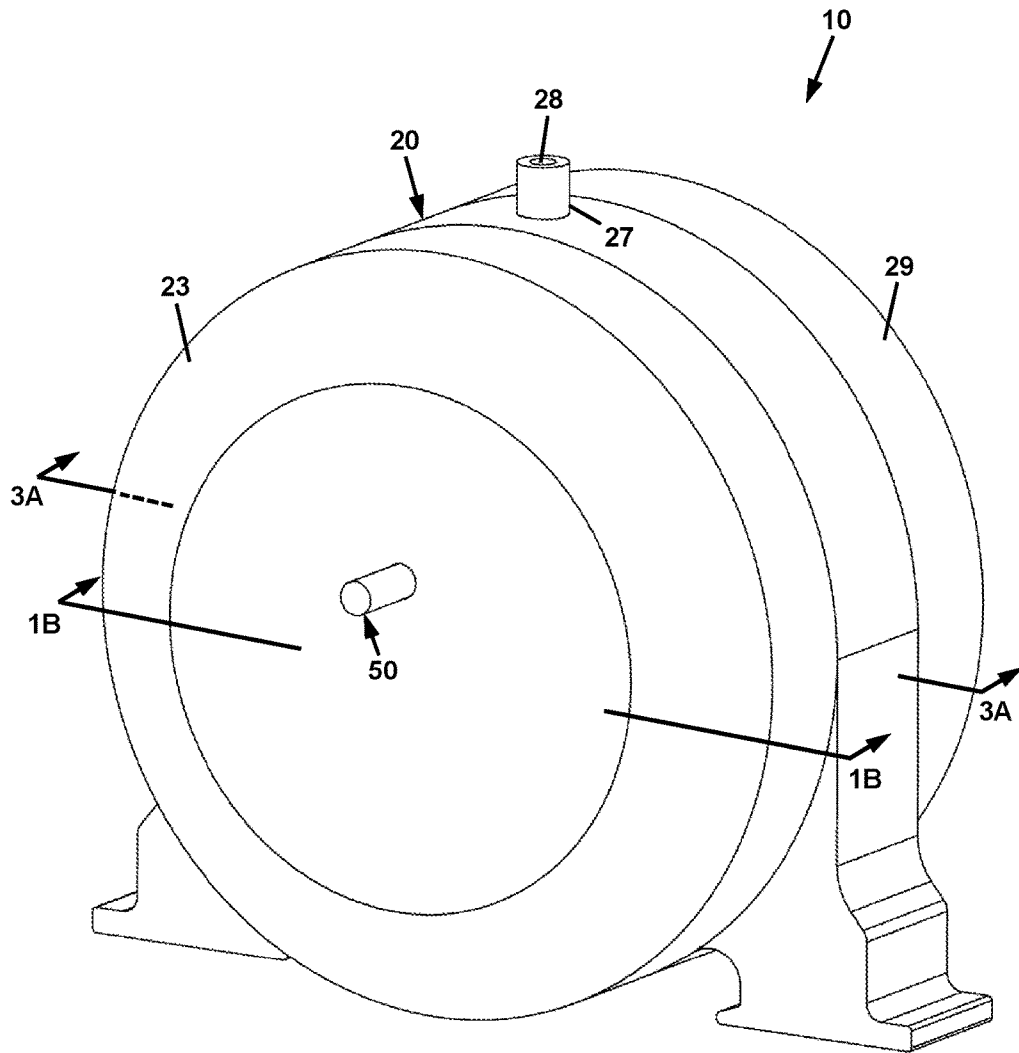

FIG. 1A

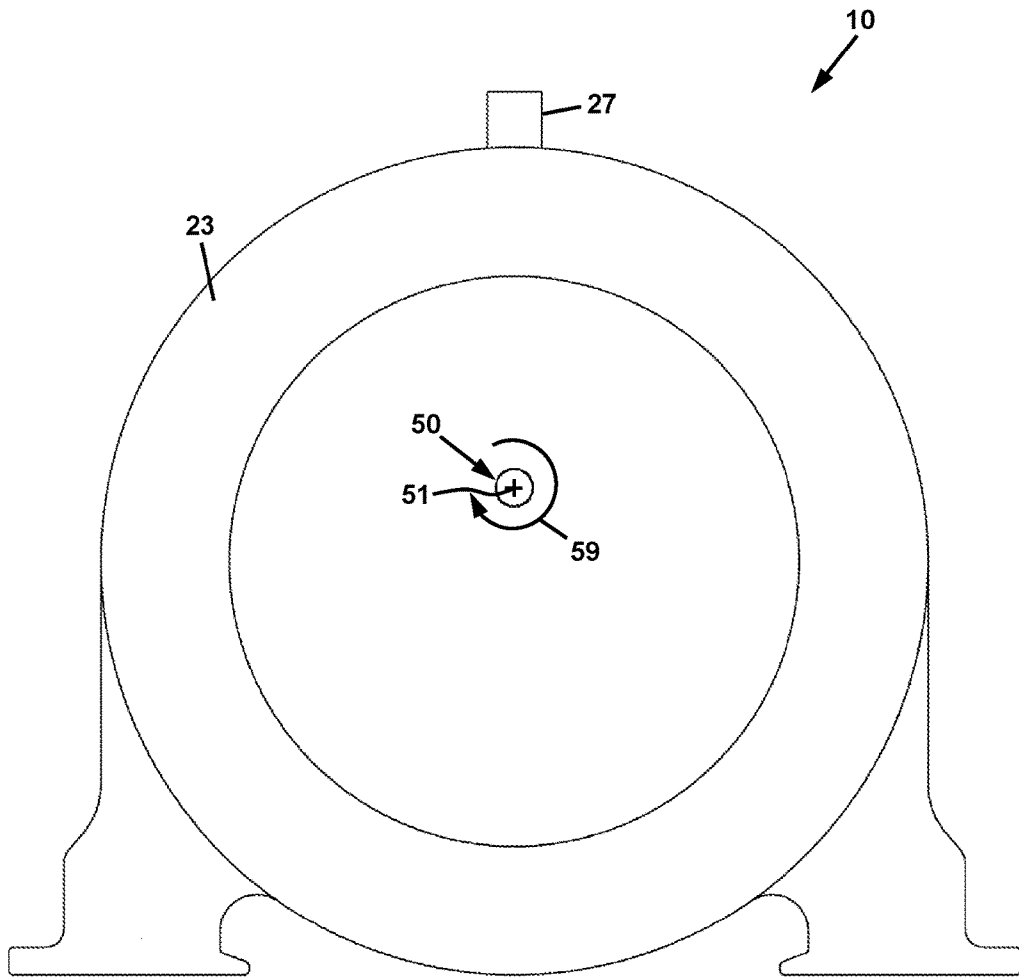

FIG. 1B

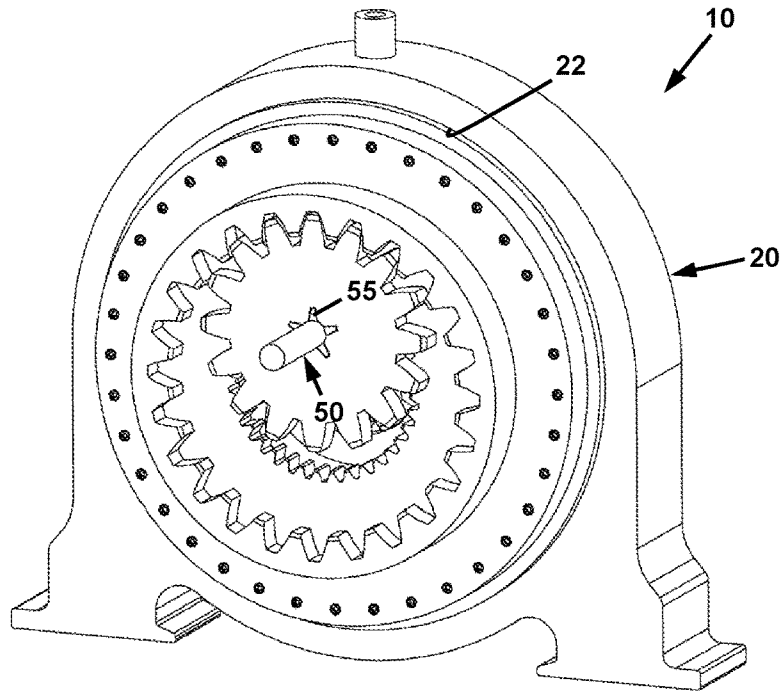

FIG. 2A

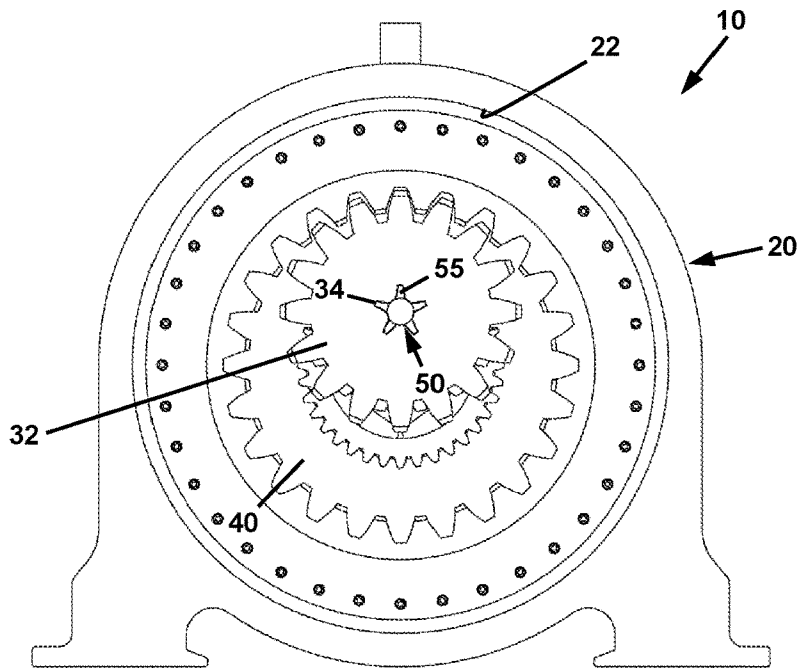

FIG. 2B

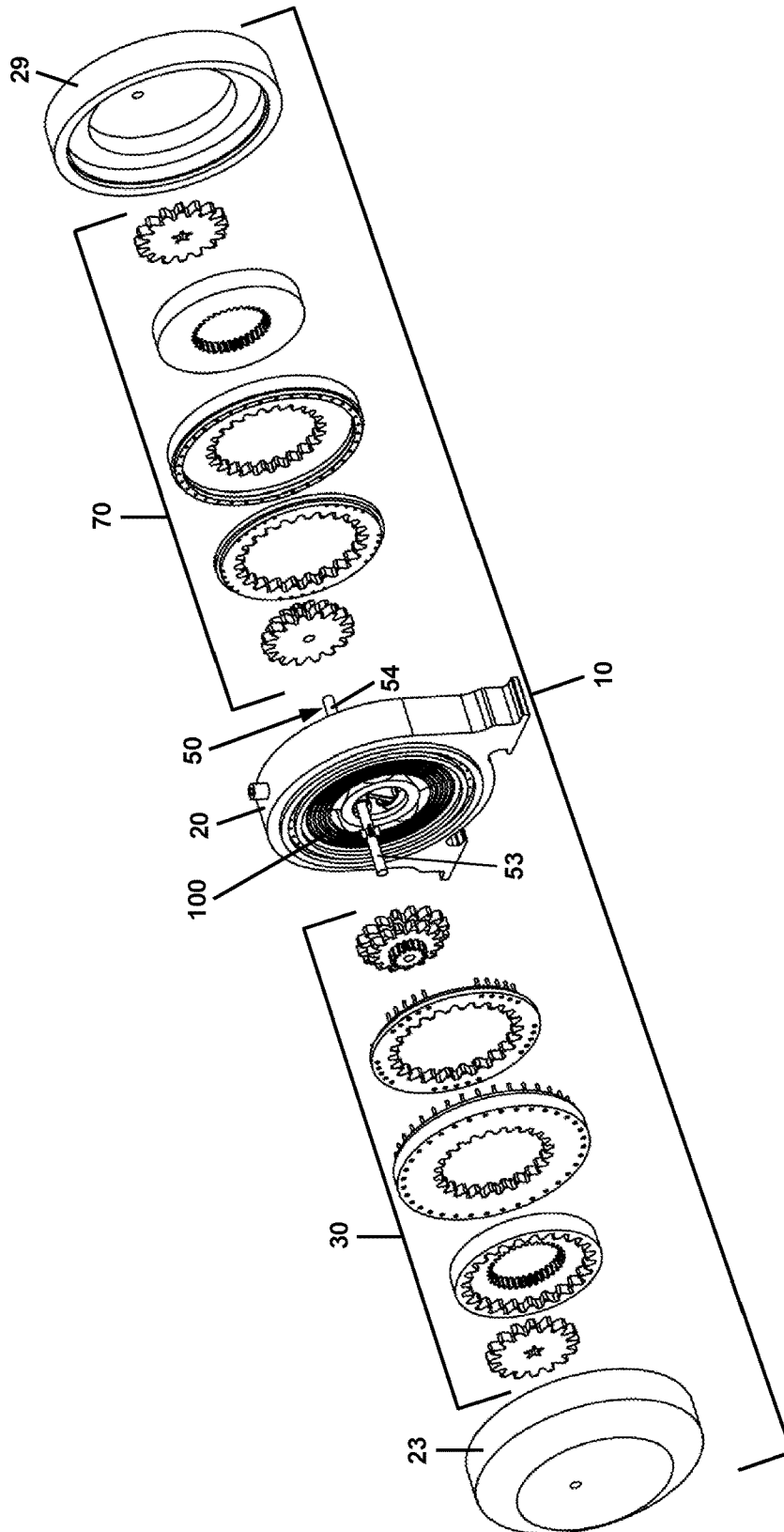

FIG. 2C

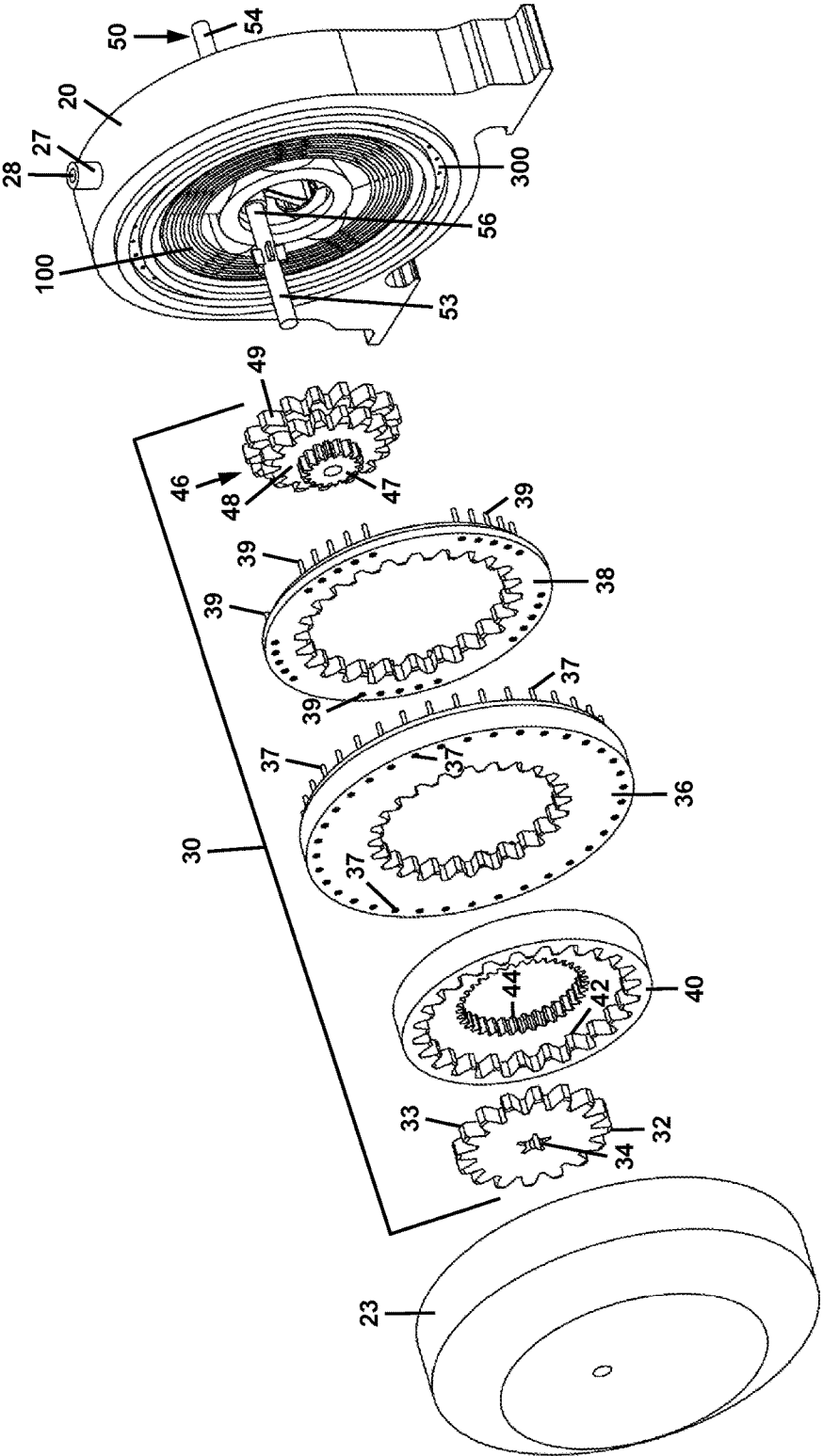

FIG. 2D

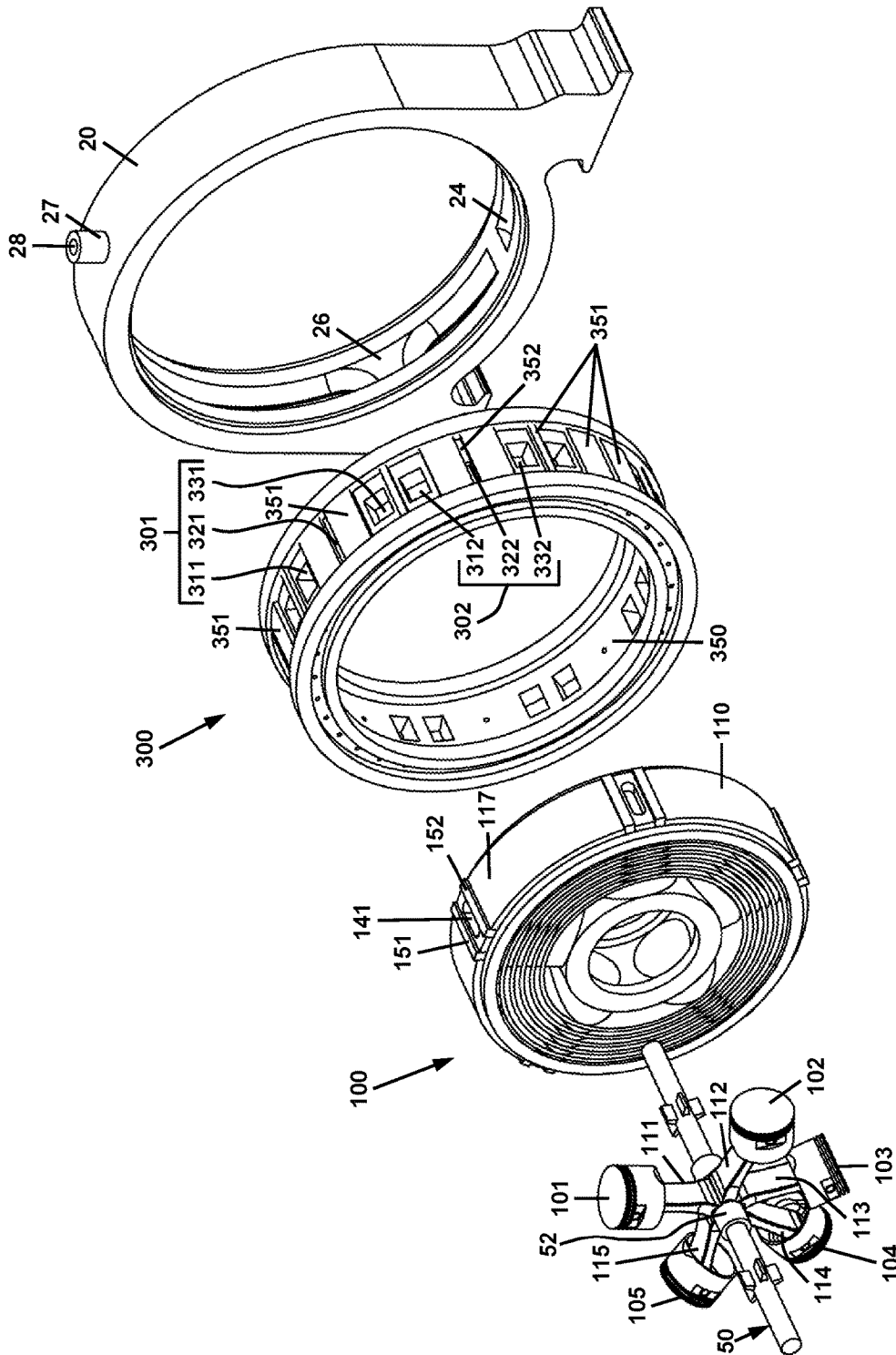

FIG. 2E

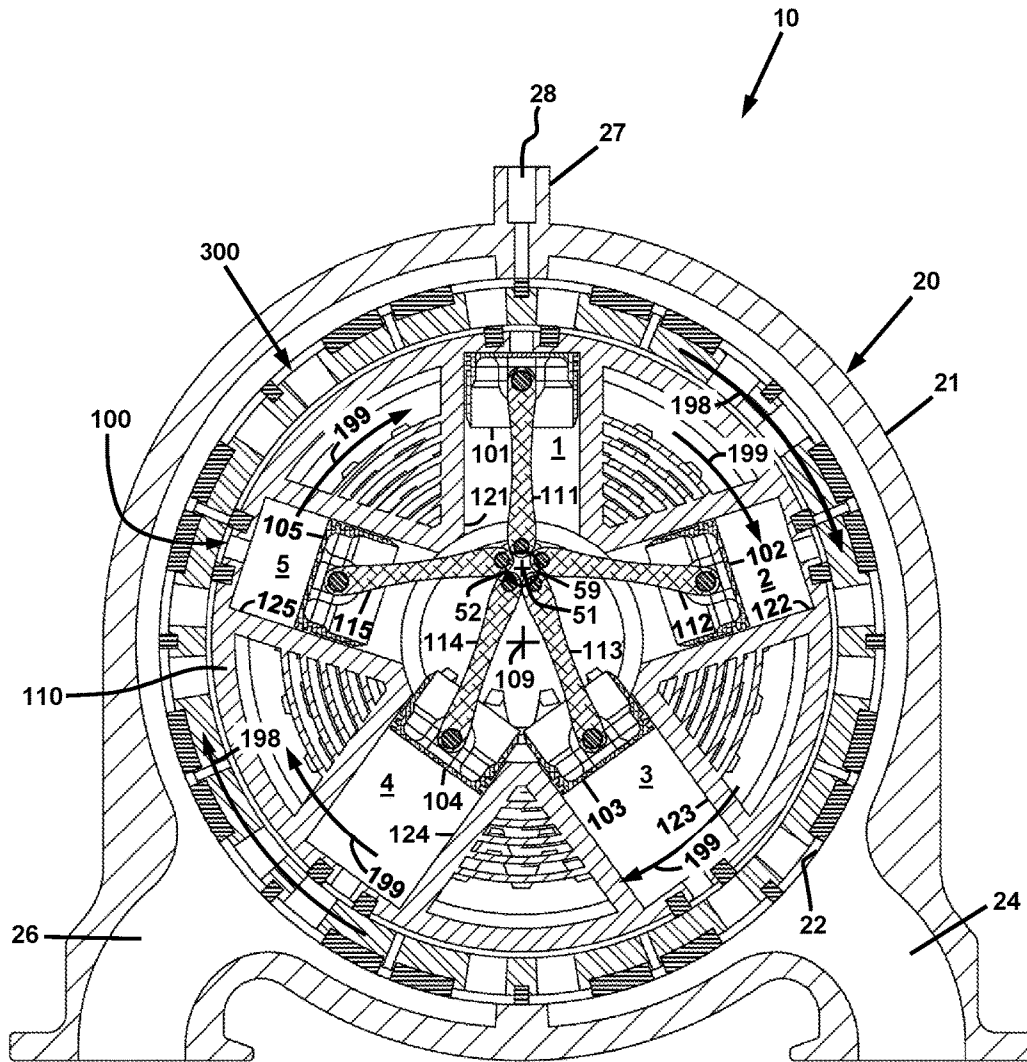

FIG. 3A

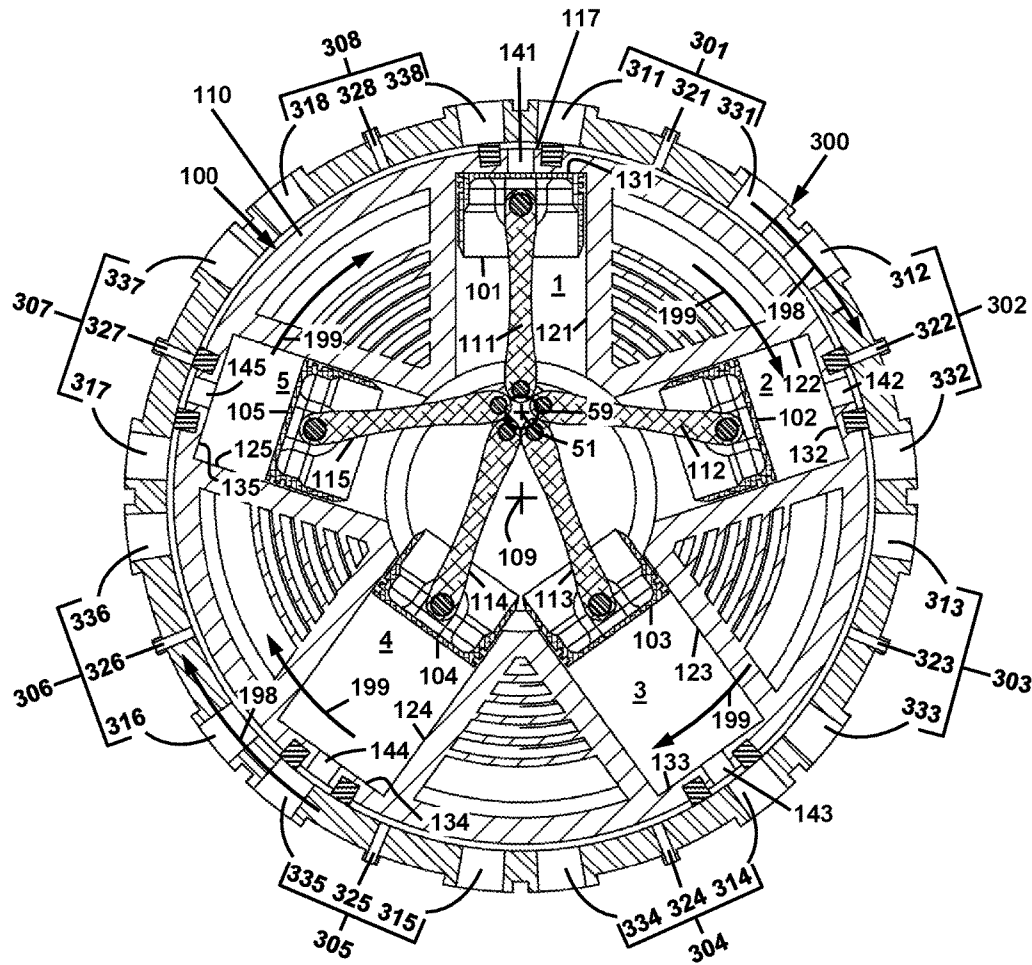

FIG. 3B

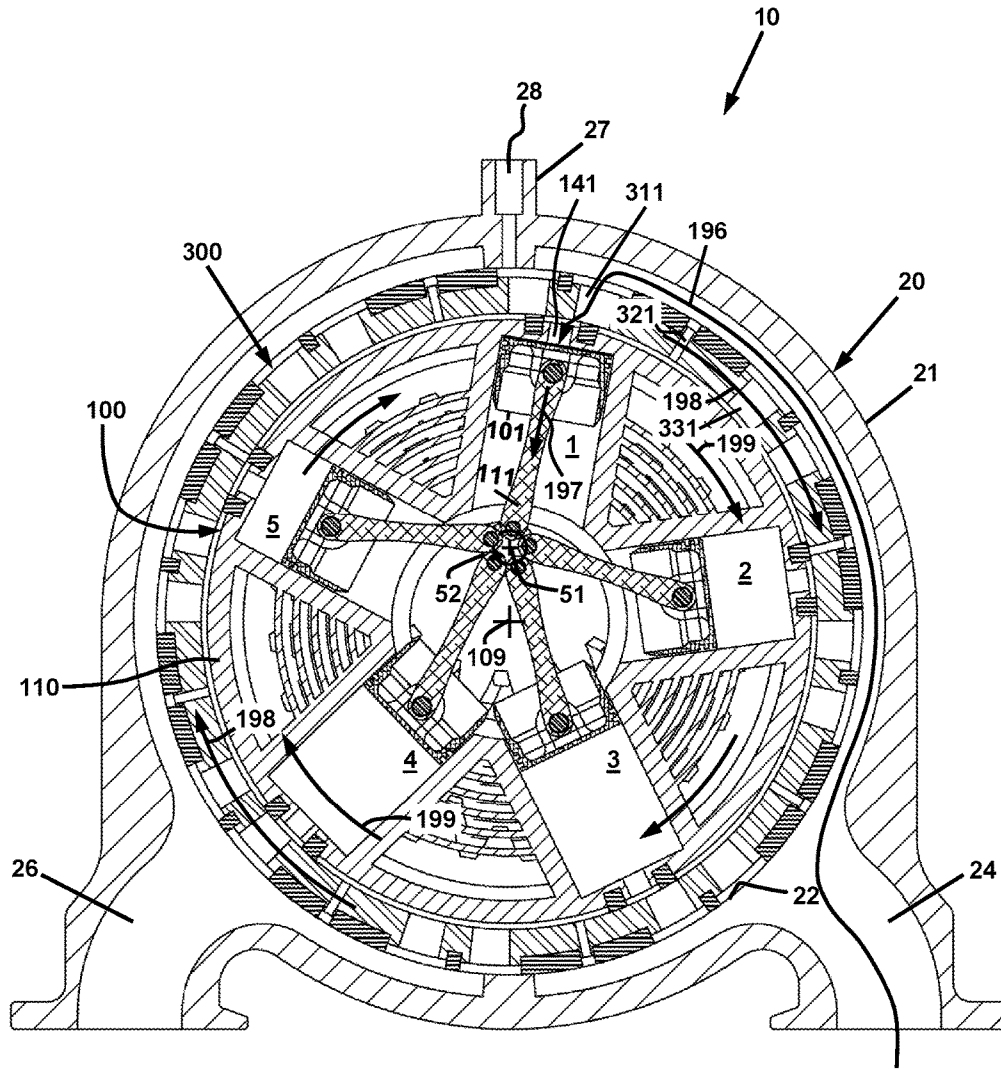

FIG. 4A

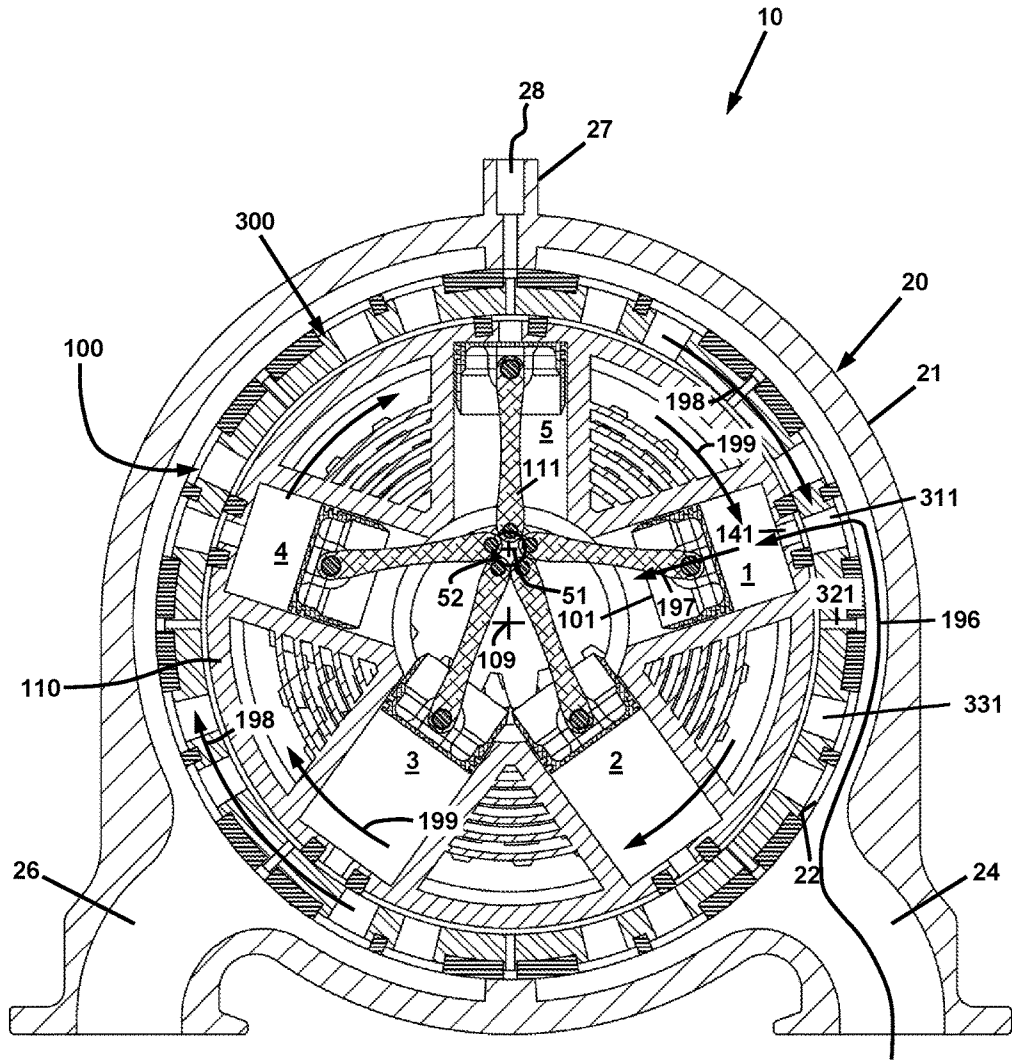

FIG. 4B

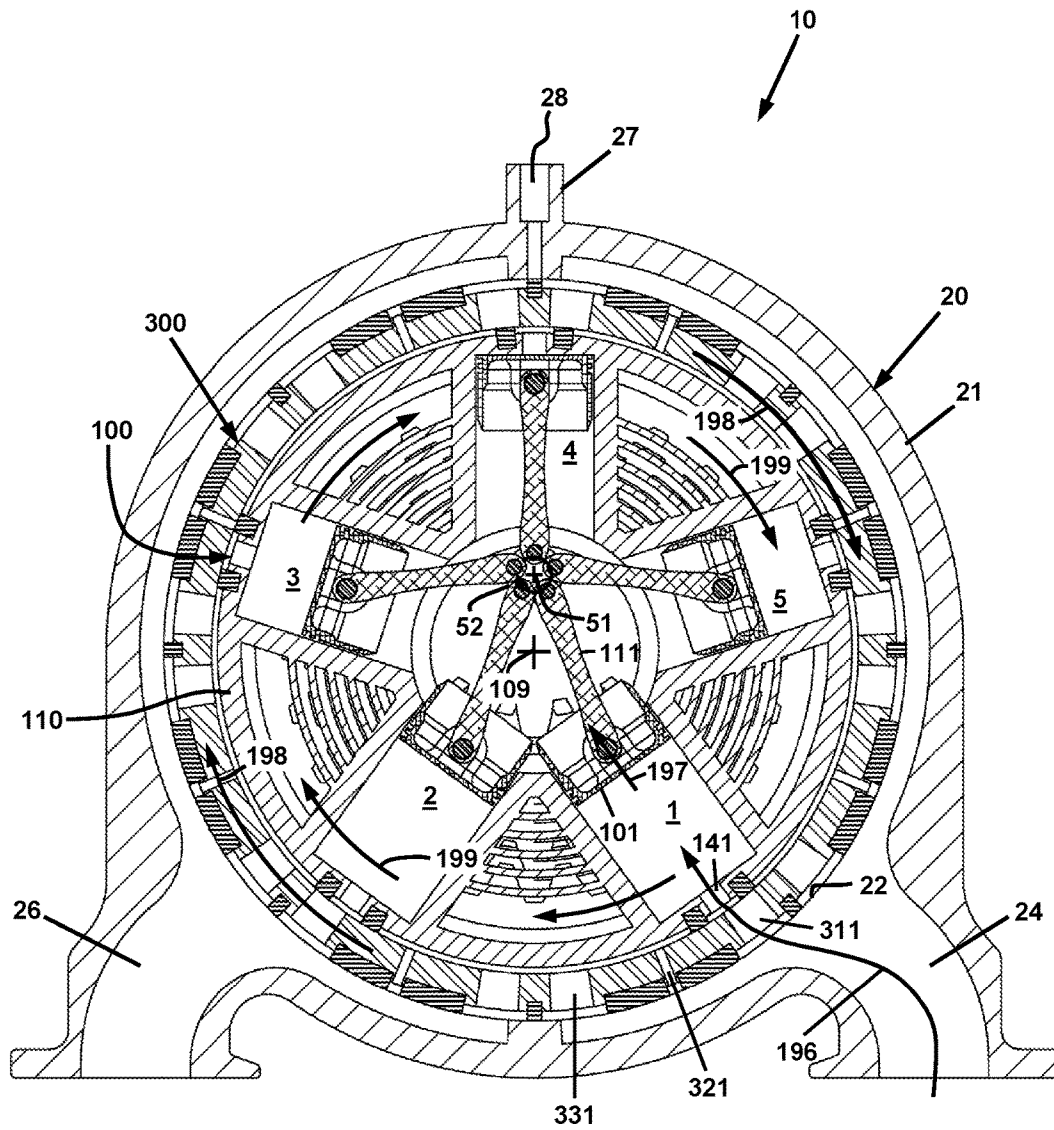

FIG. 4C

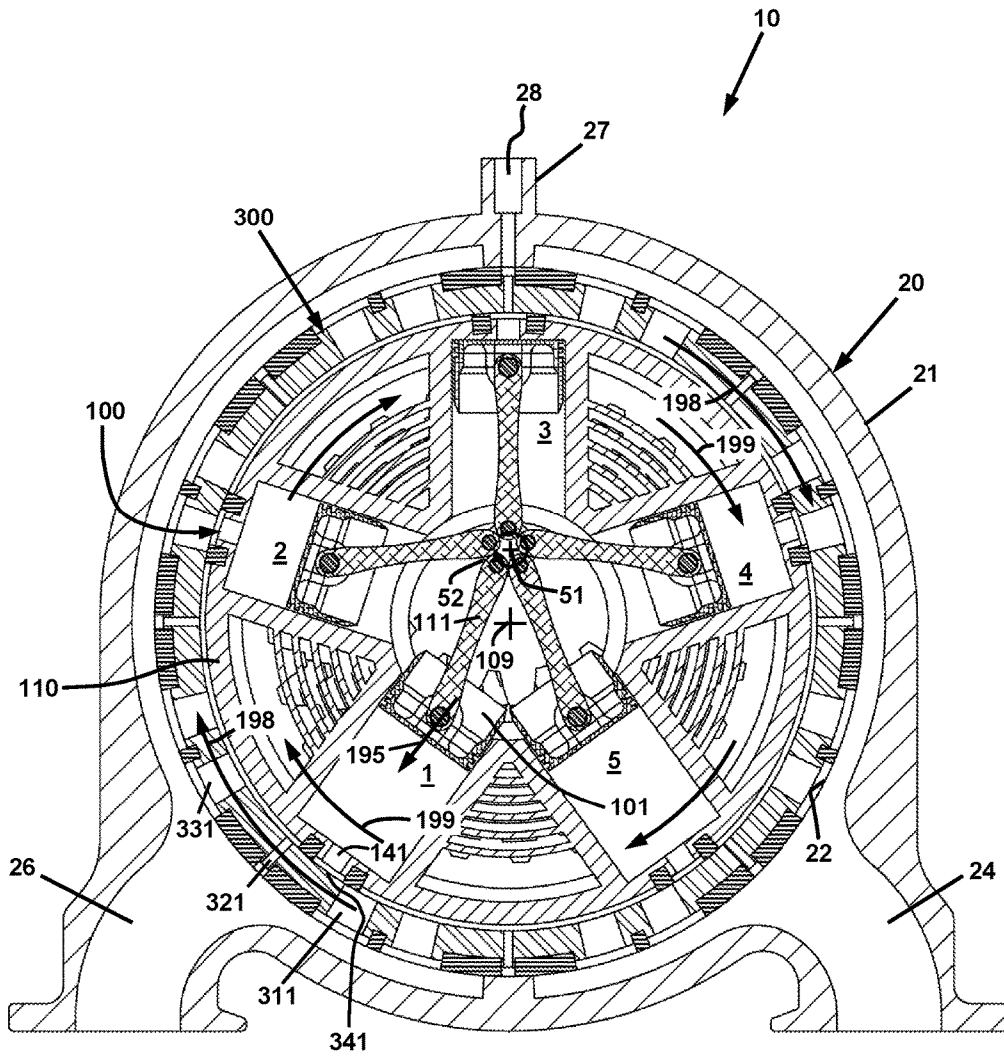

FIG. 4D

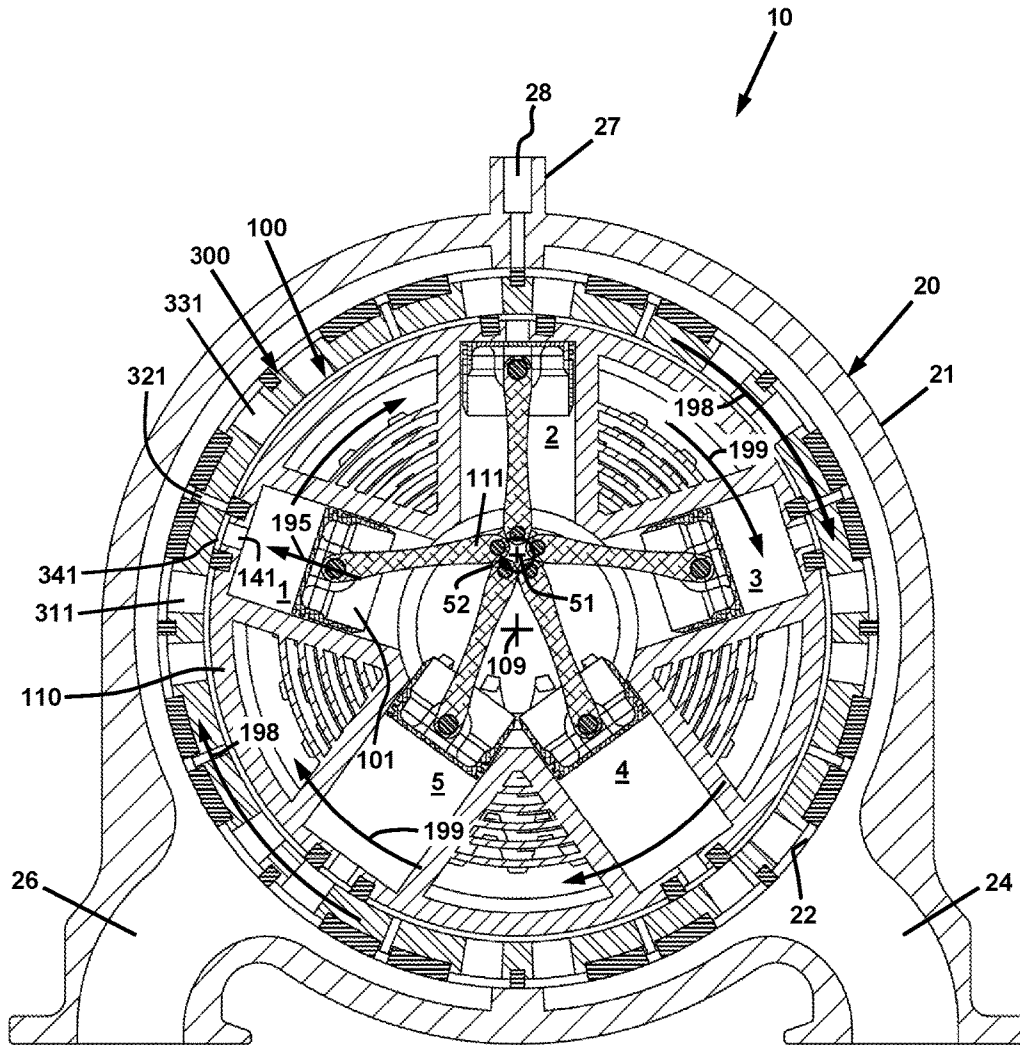

FIG. 4E

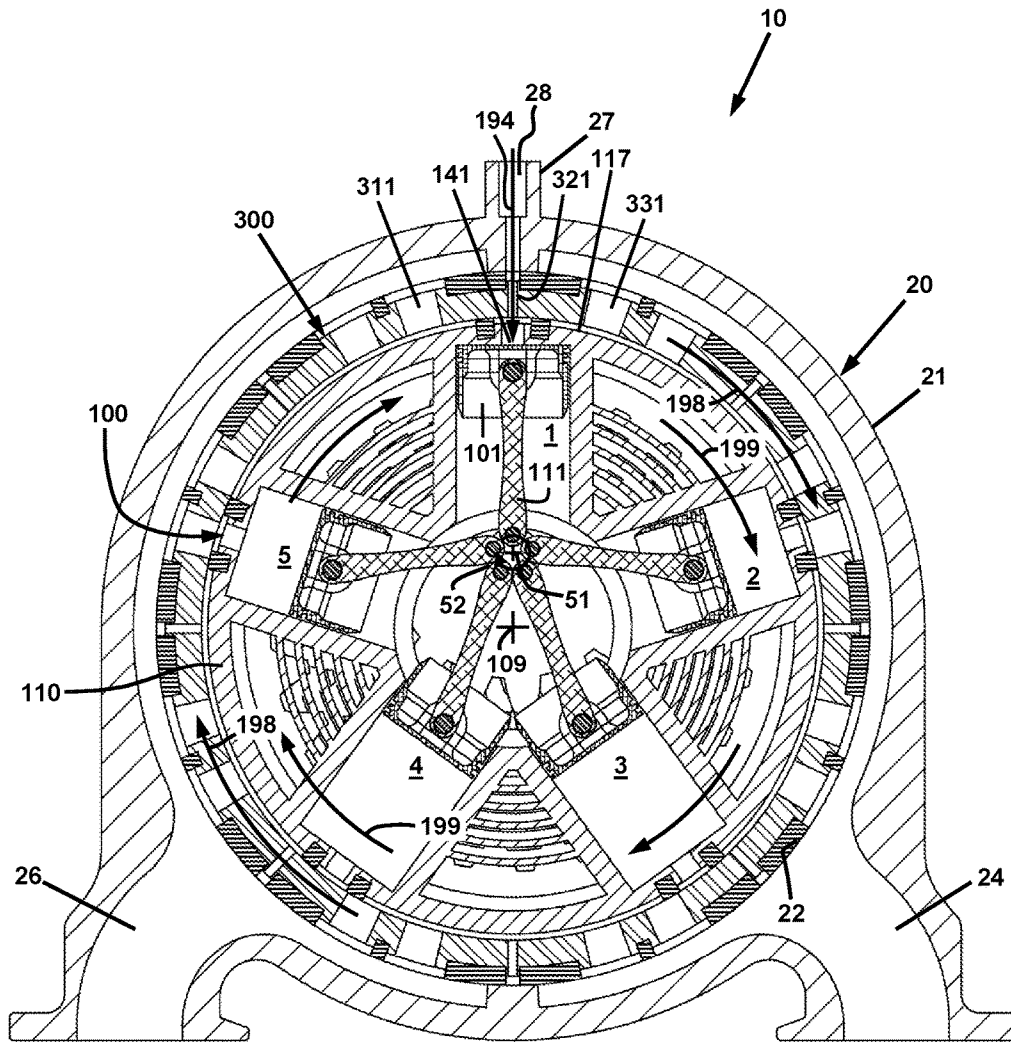

FIG. 4F

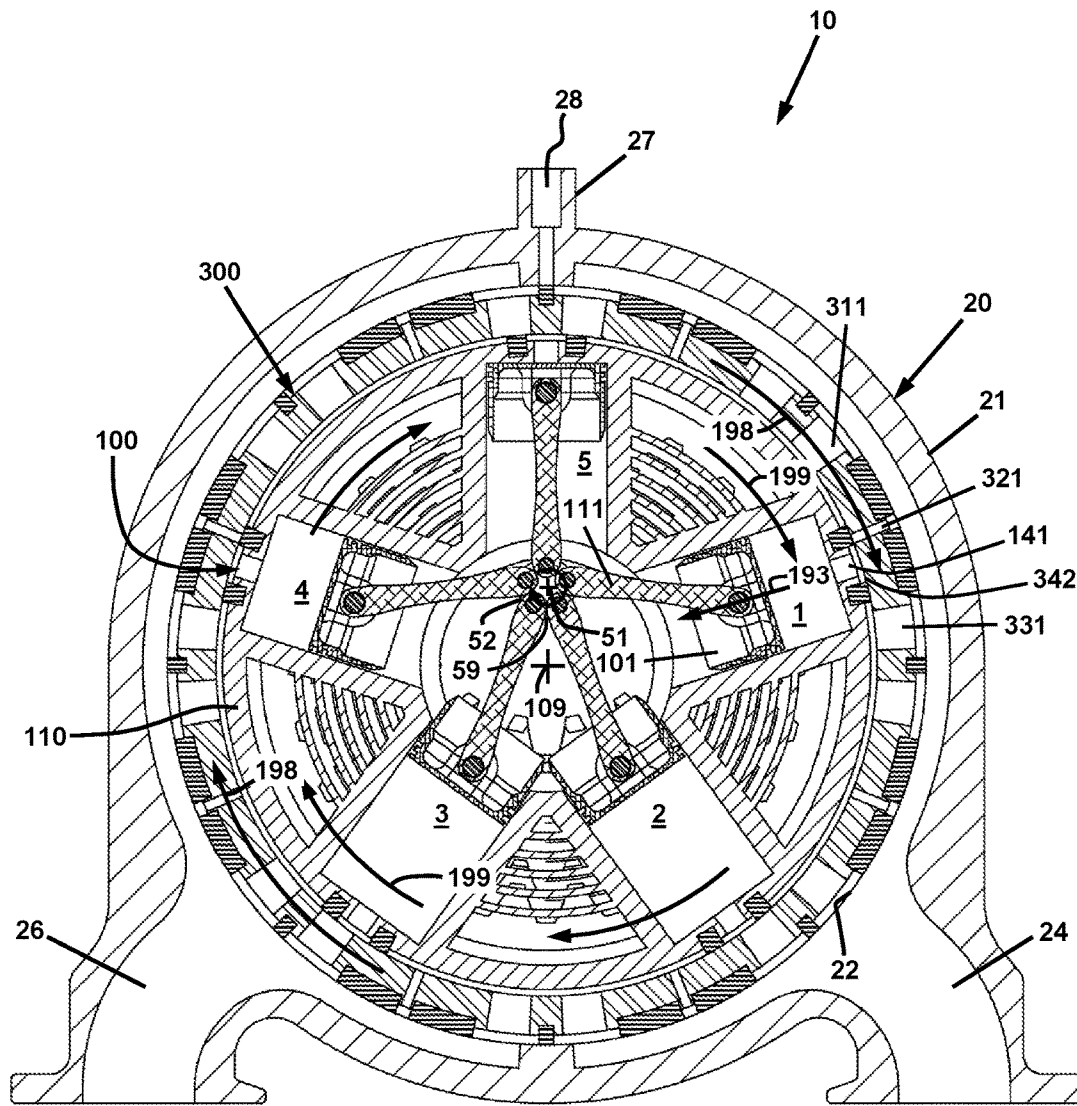

FIG. 4G

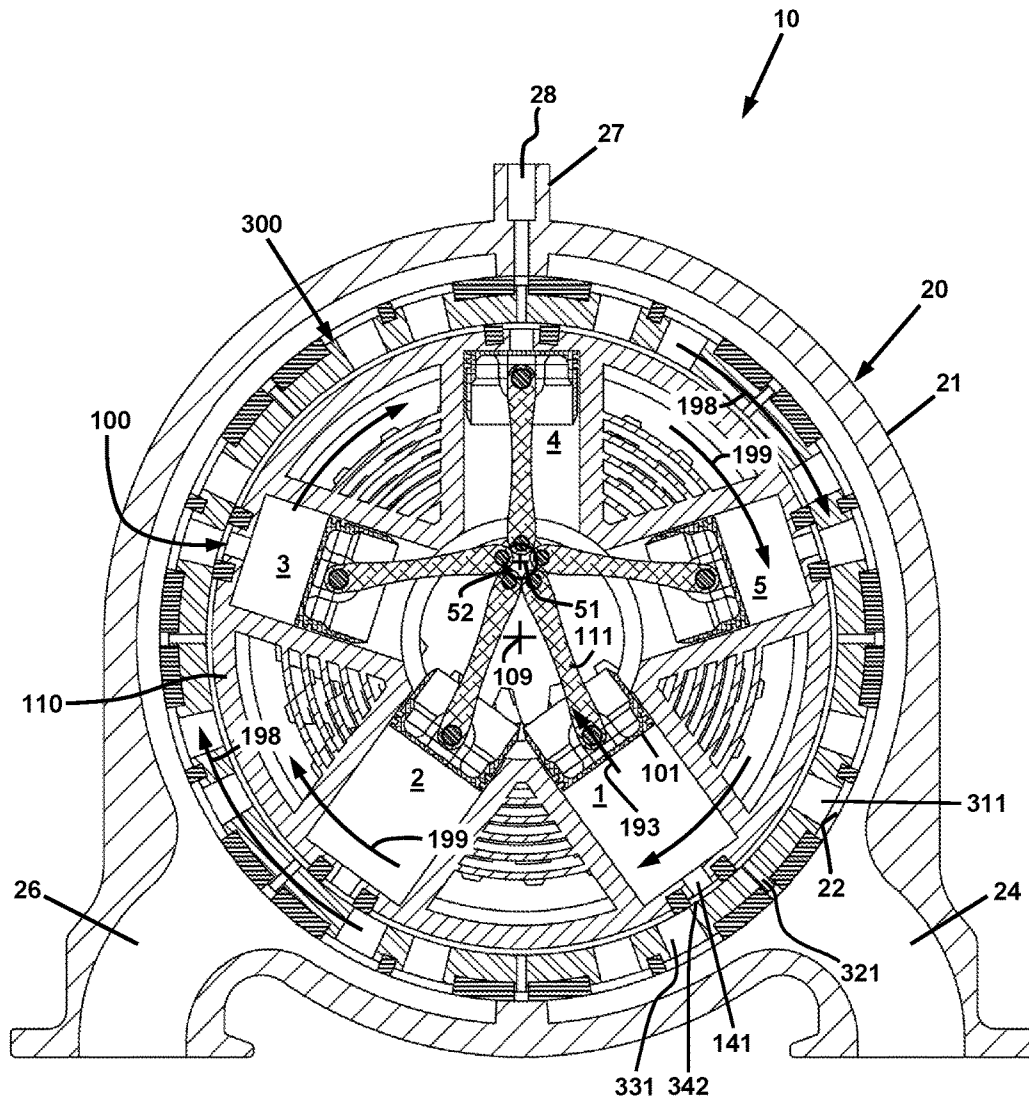

FIG. 4H

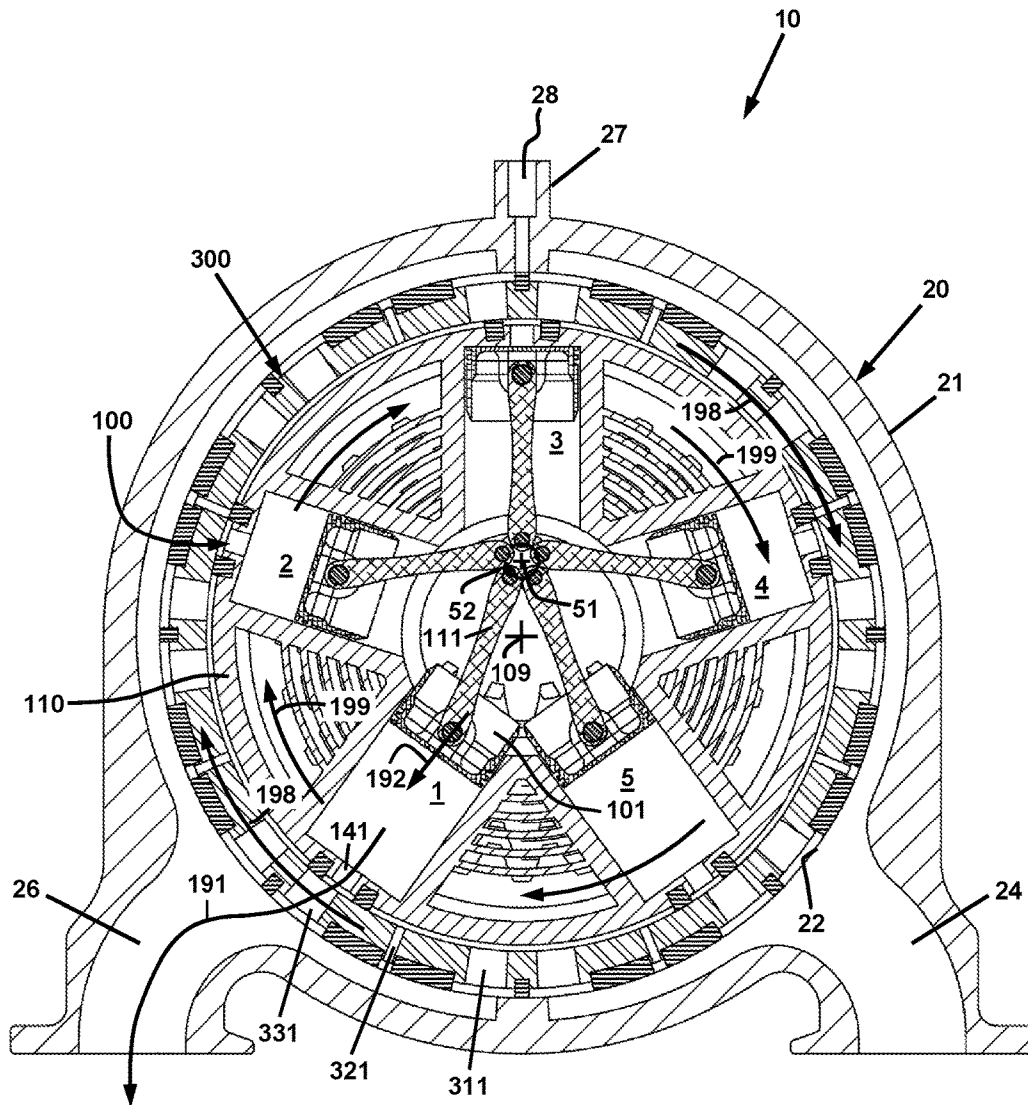

FIG. 4I

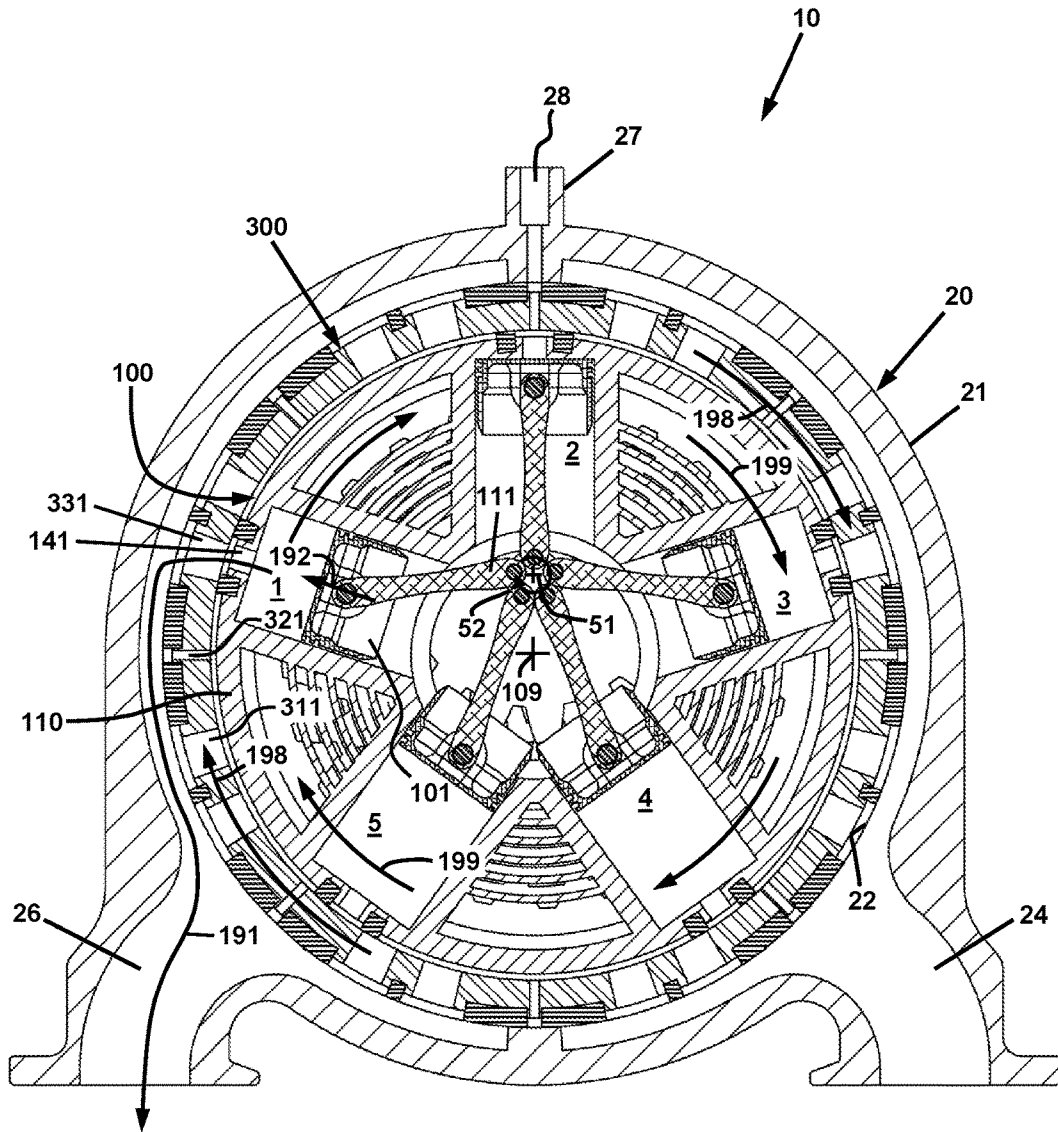

FIG. 4J

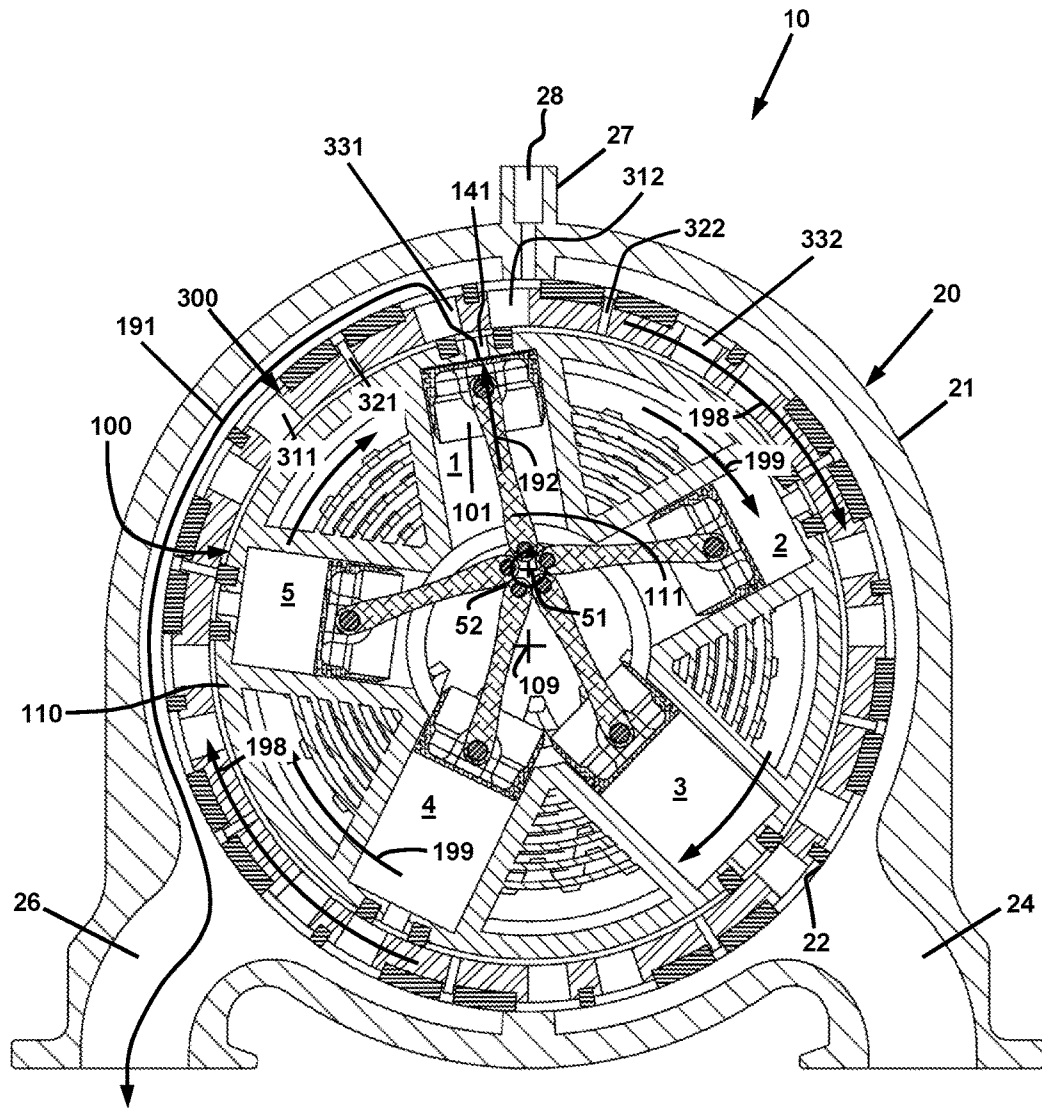

FIG. 4K

GAS FLOW AND ENERGY CONVERSION APPARATUS

CROSS-REFERENCE TO RELATED PATENT APPLICATIONS

This application is a continuation of U.S. patent application Ser. No. 14/088,424, filed on Nov. 24, 2013, and issued as U.S. Pat. No. 9,587,558 on Mar. 7, 2017, the disclosure of which is incorporated herein by reference.

BACKGROUND

Technical Field

Internal combustion engines having rotating cylinder assemblies.

Description of Related Art

Despite the ongoing advances made in energy conversion devices, the piston-based internal combustion (IC) engine remains in widespread use as a power plant for automobiles and industrial applications. It appears that the IC engine will continue to have widespread use well into the future, particularly because there remains considerable opportunity to improve its energy conversion efficiency, as well as other operational aspects.

The vast majority of IC engines currently in use have an “in-line” configuration of cylinders. Such an IC engine may have a single block of cylinders having pistons operatively connected to a crankshaft by rods, or an IC engine may have a pair of blocks of cylinders formed in a V configuration in an engine block, each of the cylinders having pistons operatively connected to a single crankshaft by rods. “V8” engines, as well as “V-twins” (two cylinder), V4s, V6s, V10s, and V12s have this configuration, and are in use today.

In an alternative configuration, an IC engine may have a rotary configuration in which a block of cylinders is connected to a central crankshaft by rods. In operation of a rotary IC engine, the entire block of cylinders rotates. The pistons of the cylinder block are connected to the crankshaft by rods, and undergo reciprocating motion during a combustion cycle, thereby causing rotation of the crankshaft and the block of cylinders.

The rotary piston engine had substantial use in early IC engine driven aircraft, but was eventually rendered obsolete by advances in alternative power plants, including turbine-based propulsion. Rotary piston engines of that era had high fuel consumption and high oil consumption. Additionally, air drag from the rotating cylinder assembly increases with the square of rotational speed, which limited the maximum RPM at which these engines could operate, thus limiting maximum power output.

Rotary engines, much like conventional in-line fixed block engines, also have undesired complexity in the components required to provide the intake of combustible air/fuel mixture, and the supply and timing of ignition energy. Most rotary engines are configured to operate with multiple spark ignition sources disposed around the rotating cylinder assembly. The timing of these ignition sources in the combustion cycles of the cylinders must be managed, adding further complexity. Additionally, many rotary engine configurations are limited to operating as two-cycle engines due to their intake and exhaust designs.

However, despite these problems, the rotary piston IC engine has certain inherent advantages over the in-line stationary cylinder block engines in single and V-configurations. Because of the lack of a heavy crankshaft as used in in-line fixed block engines, rotary piston engines run with

less vibration. They also have a high power-to-weight ratio. Additionally, the rotary piston assembly itself acts as a flywheel; thus there is no need to add the rotating mass of a solid plate flywheel, as is done in conventional in-line fixed block engines. If at least some of the problems could be solved by a rotary IC engine having an improved design, the rotary IC engine could become a valuable alternative power plant for automobiles and industrial applications, acting as a bridge to alternative energy conversion and transportation devices that will not be commercialized until well out in the future.

SUMMARY

In accordance with the present disclosure, there is provided an internal combustion engine comprising an engine block comprised of a main cavity, an intake plenum, and an exhaust plenum; a crankshaft supported within the main cavity of the engine block; a rotating piston assembly contained within the main cavity of the engine block and comprised of a rotatable cylinder housing having a housing axis of rotation and comprised of a plurality of pistons contained in combustion cylinders; and a rotating valve ring contained within the engine block and surrounding the rotating piston assembly, and comprised of valve port sets comprising intake ports, ignition energy ports, and exhaust ports communicable with each of the plurality of combustion cylinders. The rotatable cylinder housing has an axis of rotation that is parallel to and offset from the crankshaft axis of rotation.

Each of the plurality of combustion cylinders is comprised of a cylindrical side wall and a top wall formed in the cylinder housing. Each piston is contained in a combustion cylinder and is operatively connected by a piston rod to the crankshaft and reciprocable along the central axis of the respective cylindrical side wall. For each of the plurality of pistons in combustion cylinders, the piston and the cylindrical side wall and top wall of the cylinder form a variable volume combustion chamber.

By virtue of the offset of the cylinder housing axis of rotation from the crankshaft axis of rotation, in operation of the engine, rotation of the piston assembly around its axis of rotation causes the distance from the crankshaft to the cylindrical wall of each combustion cylinder to vary periodically, thereby causing each piston to reciprocate within its cylindrical wall in repeated intake, compression, power, and exhaust strokes. Additionally, the rotating piston assembly and the rotating valve ring are operatively coupled to the crankshaft such that during operation of the engine, the rotating piston assembly and the rotating valve ring rotate synchronously with rotation of the crankshaft.

Thus during operation of the engine through a combustion cycle of intake, compression, power, and exhaust strokes of the pistons, for each respective combustion cylinder, the following occurs:

INTAKE: During the intake stroke of the piston from a distal end of the cylinder to the proximal end of the cylinder, the rotating valve ring positions an intake port for the respective combustion cylinder so that the combustion chamber of the cylinder is in communication with the intake plenum, thereby causing a gas contained in the intake plenum to flow into the combustion chamber. The gas may be a combustible gas. Alternatively, the gas may be air, oxygen, or another reactive gas that reacts with a fuel in a combustion chemical reaction.

COMPRESSION: During the compression stroke of the piston from the proximal end of the cylinder to the distal end of the cylinder, the rotating valve ring positions a first barrier wall that seals the top wall of the combustion cylinder, thereby causing compression of the gas in the combustion chamber as the piston moves from the proximal end of the cylinder to the distal end of the cylinder.

IGNITION: At substantially the end of the compression stroke of the piston, the rotating valve ring positions an ignition energy port in communication with the combustion chamber and an ignition energy source, thereby delivering ignition energy to the gas and causing the gas in the combustion chamber to ignite. If the gas is a combustible gas, the ignition energy may be from a spark plug. If the gas is air or another gas containing oxygen or another reactive gas, the ignition energy may be from direct injection of a fuel, such as a diesel fuel, which ignites under the high compression in the cylinder.

POWER: During the power stroke of the piston from a distal end of the cylinder to the proximal end of the cylinder, the gas combusts while the rotating valve ring positions a second barrier wall that seals the top wall of the combustion cylinder, thereby causing an increase in pressure within the combustion chamber, thereby applying a force on the piston and the connecting rod in the proximal direction, and thereby applying a torque on the crankshaft to cause crankshaft rotation.

EXHAUST: During the exhaust stroke of the piston from the proximal end of the cylinder to the distal end of the cylinder, the rotating valve ring positions an exhaust port for the respective combustion cylinder so that the combustion chamber of the cylinder is in communication with the exhaust plenum, thereby causing combustion gas contained in the combustion chamber to flow into the exhaust plenum and out of the engine.

These and other aspects of the IC engine of the present disclosure are provided subsequently herein.

BRIEF DESCRIPTION OF THE DRAWINGS

The present disclosure will be provided with reference to the following drawings, in which like numerals refer to like elements, and in which:

FIG. 1A is a perspective view of an embodiment of the internal combustion engine of the present disclosure;

FIG. 1B is a front elevation view of the engine embodiment of FIG. 1A, taken along line 1B-1B of FIG. 1A;

FIGS. 2A and 2B are perspective and front elevation views as in FIGS. 1A and 1B, but with a front and rear covers of the engine removed to show certain drive gearing of the engine;

FIG. 2C is an exploded view of the engine of FIG. 1A, further depicting the drive gearing of the engine;

FIG. 2D is a portion of the exploded view of FIG. 2C, depicting the front drive gearing of the engine;

FIG. 2E is an exploded view of a portion of the engine of FIG. 1A, depicting the engine block, rotating valve ring, rotating cylinder housing, and piston and crankshaft assembly;

FIG. 3A is a front elevation cross-sectional view of the engine embodiment of FIG. 1A, taken along line 3A-3A of FIG. 1A;

FIG. 3B is a front elevation cross-sectional view depicting only a rotating piston assembly and rotating valve ring of the engine embodiment of FIG. 1A, also taken along line 3A-3A of FIG. 1A;

FIGS. 4A-4K are a sequence of front elevation cross-sectional views of the engine embodiment of FIG. 1A taken along line 3A-3A of FIG. 1A, and showing the operational cycle of intake stroke, compression stroke, ignition, power stroke, and exhaust stroke of the engine.

The present invention will be described in connection with certain preferred embodiments. However, it is to be understood that there is no intent to limit the invention to the embodiments described. On the contrary, the intent is to cover all alternatives, modifications, and equivalents as may be included within the spirit and scope of the invention as defined by the appended claims.

DETAILED DESCRIPTION

For a general understanding of the present invention, reference is made to the drawings. In the drawings, like reference numerals have been used throughout to designate identical elements. In the following disclosure, certain components may be identified with adjectives such as "front", "rear," "top," "upper," "bottom," "lower," "left," "right," etc. These adjectives are provided in the context of the orientation of the drawings, which is arbitrary. The description is not to be construed as limiting the engine to use in a particular spatial orientation. The instant engine may be used in orientations other than those shown and described herein. Additionally, certain components of the engine as depicted in the drawings may be larger or smaller relative to other components; the drawings are not to be considered as drawn to scale.

Additionally, a "gas" as used herein when referring to a compressible fluid being taken into a combustion chamber during an intake cycle of the engine is meant to indicate a compressible fluid that may only have gaseous molecules, but that may also include fine droplets of liquid phase molecules (typically liquid fuel molecules) in droplet forms such as mists and aerosols.

Referring first to FIGS. 1A, 3A, and 3B, the internal combustion engine 10 is comprised of an engine block or casing 20, a rotating piston assembly 100 and a rotating valve ring 300. The engine block 20 may include a front cover 23 and a rear cover 29 that enclose gear sets that engage with each other and drive the rotating piston assembly 100 and rotating valve ring 300 relative to each other and relative to the engine block 20. The function of these gear sets will be explained subsequently herein.

The engine block 20 is further comprised of a main cavity 22 that contains the rotating piston assembly 100 and a rotating valve ring 300. The engine block 20 may also include an intake plenum 24 that is configured to receive a combustible gas from a fuel source (not shown) and direct the combustible gas through the valve ring 300 and into the respective combustion cylinders 1, 2, 3, 4, and 5, where combustion occurs during the respective power strokes of the combustion cylinders 1-5. In an alternative embodiment (not shown), the intake plenum 24 may be provided as a separate intake manifold piece that is joined to the engine block 20. The fuel source (not shown) may be carburetor or a fuel injector that is supplied with a gaseous combustible fuel or a liquid combustible fuel that is atomized and evaporates before or during combustion in the combustion cylinders. The fuel injector may be located in a manifold (not shown) that is joined to the intake plenum, or the fuel

injector may be mounted in a port (not shown) that extends through the external wall **21** of the engine block **20** into the plenum **24**.

The engine block **20** may also include an exhaust plenum **26** that is configured to receive a combustion exhaust gas from the respective combustion cylinders 1, 2, 3, 4, and 5 through the valve ring **300** and direct the exhaust gas out of the engine block **20** into the ambient atmosphere, or into an emissions abatement device (not shown), such as a catalytic converter. In an alternative embodiment (not shown), the exhaust plenum **26** may be provided as a separate exhaust header piece that is joined to the engine block **20**.

The engine block may be further comprised of an ignition source port **28** for directing ignition energy into the combustion cylinders 1-5 during operation of the engine **10**. The ignition source port **28** may be formed in a boss **27** that extends outwardly from the external wall **21** of the engine block **20**. The ignition source port **28** may be provided with threads (not shown) for engagement with corresponding threads of a spark plug (not shown), which may be used to provide the ignition energy.

The engine **10** is further comprised of a crankshaft **50** that is driven by the action of the pistons during their respective power strokes as will be described subsequently herein. The crankshaft **50** is supported within the main cavity **22** of the engine block. In the embodiment of the engine **10** depicted in FIGS. 1-4K, the crankshaft may be supported by bearings (not shown) in the front cover **23** and rear cover **29**. In an alternative embodiment (not shown), the bearings may be provided as "main bearings" that are supported by the engine block **20**.

Referring in particular to FIGS. 3A and 3B, the rotating piston assembly **100** is contained within the main cavity **22** of the engine block **20**, and is comprised of a rotatable cylinder housing **110** containing a plurality of pistons enclosed within combustion cylinders. During operation of the engine **10**, the rotating piston assembly **100** rotates about the housing axis of rotation **109** as indicated by arrows **199**. In the embodiment of engine **10** depicted in FIGS. 1-4K, the engine **10** is provided with five pistons **101**, **102**, **103**, **104**, and **105** enclosed respectively within combustion cylinders 1, 2, 3, 4, and 5. It is to be understood that the engine **10** may be comprised of an alternative number of combustion cylinders, and that the embodiment of engine **10** depicted in FIGS. 1-4K is to be considered as exemplary and not limiting. It is further noted that an odd number of cylinders is preferred because an even number of cylinders will not produce a smooth ignition firing pattern and may also require an irregular pattern of the ports in the rotating valve ring that may adversely affect engine life.

Each of the plurality of combustion cylinders 1-5 is comprised of a cylindrical side wall and a top wall formed in the cylinder housing **110**. The pistons **101-105** contained in respective combustion cylinders 1-5 are operatively connected by respective piston rods **111**, **112**, **113**, **114**, and **115** to a radial flange **52** of the crankshaft **50**. The connections of the piston rods **111-115** to the radial flange **52** are offset from the axis of rotation **51** of the crankshaft **50** so that during the respective power strokes of the pistons **101-105**, torque is applied to the crankshaft **50**, thereby resulting in crankshaft rotation as indicated by arrow **59**. The pistons **101-105** are reciprocable along the central axes of their respective cylindrical side walls **121**, **122**, **123**, **124**, and **125**. For each of the plurality of pistons **101-105** in combustion cylinders 1-5, the piston and the cylindrical side wall and top wall of the cylinder form a variable volume combustion chamber.

Referring again to FIG. 3A, the rotating valve ring **300** is contained within the engine block **20** and surrounds the rotating piston assembly **100**. The rotating valve ring **300** is comprised of intake ports, ignition energy ports, and exhaust ports corresponding to each of the plurality of combustion cylinders 1-5, which will be explained in detail subsequently herein. The rotating valve ring **300** and rotatable cylinder housing **110** share a common axis of rotation **109**, with the rotating valve ring rotating around axis **109** as indicated by arrows **198**. This common axis of rotation **109** is parallel to and offset from the crankshaft axis of rotation **51**.

By virtue of the offset of the cylinder housing axis of rotation **109** from the crankshaft axis of rotation **51**, in operation of the engine **10**, rotation of the piston assembly **100** around its axis of rotation **109** causes the distance from the crankshaft **50** to the respective cylindrical walls **121-125** of each of the combustion cylinders 1-5 to vary periodically, thereby causing each piston **101-105** to reciprocate within its cylindrical wall in repeated intake, compression, power, and exhaust strokes. Additionally, the rotating piston assembly **100** and the rotating valve ring **300** are operatively coupled to the crankshaft **50** by gearing such that during operation of the engine **10**, the rotating piston assembly **100** and the rotating valve ring **300** rotate synchronously with rotation of the crankshaft **50**.

These principles will now be explained in detail with reference to FIGS. 2A-2E, FIG. 3B, and FIGS. 4A-4K. Turning first to the rotation of the rotating piston assembly **100** and the rotating valve ring **300**, and referring in particular to FIGS. 2A-2E, the engine **20** is comprised of at least a front gear set **30**, which operatively couples the rotation of the crankshaft **50** to the rotating piston assembly **100** and the rotating valve assembly **300**. The front gear set **30** is engaged with the front portion **53** of the crankshaft **50**. The engine may be further comprised of a rear gear set **70** that is a mirror image of the front gear set **30**. Although only one gear set is needed to obtain the desired rotational relationship between the crankshaft **50**, rotating piston assembly **100**, and the rotating valve assembly **300**, the use of a second gear set may provide greater reliability, less wear of the gears, and a smoother operation of the engine due to the "flywheel effect" of the additional gears.

The operation of the front gear set **30** will now be described with reference in particular to FIG. 2D, with it being understood that the operation of the rear gear set **70** occurs in the same manner. A first principle of operation of engine **10** is that rotation of the crankshaft **50** drives rotation of both the rotating piston assembly **100**, and the rotating valve ring. Other than rotational motion, the crankshaft **50** is otherwise in a fixed position with respect to the engine block **20** and the front cover **23** and rear cover **29**. In the embodiment of the engine **10** shown in the drawings, the crankshaft **50** is supported by bearings (not shown) in the front cover **23** and rear cover **29**. In an alternative embodiment (not shown), the bearings may be provided as "main bearings" that are supported by the engine block **20**. In either case, the crankshaft **50** rotates within the engine block **20**, and front and rear covers **23** and **29**.

Shaft gear **32** is fixed to crankshaft **50**, and is directly driven by crankshaft **50**, by virtue of engagement of drive star **55** of crankshaft **50** with drive star cutout **34** in shaft gear **32**. Thus the drive star **55** serves as a means of direct connection between the shaft gear **32** and the crankshaft **50**. Valve ring annular gear **36** is joined to rotating valve ring **300** by suitable fasteners **37**; thus when valve ring annular gear **36** is driven rotationally, rotating valve ring **300** also rotates. In like manner, piston annular gear **38** is joined to

rotating piston assembly **100** by suitable fasteners **39**; thus when piston annular gear **38** is driven rotationally, rotating piston assembly **100** also rotates.

The operation of the gear set **30** during the operation of engine **10** will now be described. It is to be understood that the operation of gear set **30** is meant to be exemplary and not limiting. The various gear sets may have different ratios and configurations, depending upon the number of cylinders in the engine **10**, and the number of valve port sets in the rotating valve ring **300**.

Referring to FIGS. **2B**, **2D**, and **2E**, a single rotation of crankshaft **50** results in a single rotation of shaft gear **32**, by virtue of engagement of drive star **55** of crankshaft **50** with drive star cutout **34** in shaft gear **32**. Double annular gear **40** is comprised of an inwardly directed outer gear **42** that is engaged with the teeth **33** of shaft gear **32**. Outer gear **42** has 24 teeth, and shaft gear **32** has 16 teeth; hence a single rotation of crankshaft **50** results in a $\frac{2}{3}$ rotation of double annular gear **40**.

Double annular gear **40** is also comprised of an inner gear **44** that is engaged with a front gear **47** of main gear set **46**, which rides rotationally on the central region **56** of crankshaft **50**. Inner gear **44** has 36 teeth, and front gear **47** has 16 teeth. Thus the single rotation of crankshaft **50** that results in a $\frac{2}{3}$ rotation of double annular gear **40** also causes $\frac{2}{3} \times 36/16$ rotations, i.e. $1\frac{1}{2}$ rotations of front gear **47**, as well as middle gear **48** and rear gear **49** of main gear set **46**.

It is noted that the position of double annular gear **40** may be fixed by its engagement with shaft gear **32** and main gear **46**, and in the axial direction by shaft gear **32** and valve ring annular gear **36**. Alternatively, double annular gear may be supported by a bearing (not shown) that is provided in engine block **20** or cover **23**.

Rear gear **49** of main gear set **46** is engaged with piston annular gear **38**. Rear gear **49** has 16 teeth, and piston annular gear **38** has 24 teeth. Thus the single rotation of crankshaft **50** that results in $1\frac{1}{2}$ rotations of rear gear **49** also results in $1.5 \times 16/24$ rotations, i.e., one rotation of piston annular gear **38**, as well as rotating piston assembly **100**. Thus crankshaft **50** and rotating piston assembly **100** rotate in unison, but on rotational axes that are offset from each other by virtue of the arrangement of the gears.

Middle gear **48** is engaged with valve ring annular gear **36**. Middle gear **48** has 15 teeth, and valve ring annular gear **36** has 24 teeth. Thus the single rotation of crankshaft **50** that results in $1\frac{1}{2}$ rotations of middle gear **48** also results in $1.5 \times \frac{15}{24}$ rotations, i.e., $\frac{15}{16}$ rotation of valve ring annular gear **36**, as well as rotating valve ring **300**.

Because the engine **10** operates as a four cycle engine, two rotations of the rotating piston assembly **100** and the crankshaft **50** occur for each combustion cycle, while the rotating valve ring **300** rotates $1\frac{7}{8}$ times. The rotational ratio of the rotating cylinder assembly **100** to the rotating valve ring **300** is thus $16/8:15/8$, or $16:15$. This difference between the rotational rates of the rotating cylinder assembly **100** to the rotating valve ring **300** provides the desired intake valve, ignition, and exhaust valve timing during the combustion cycle, as will be explained subsequently herein.

The operation of the rotating piston assembly **100** in combination with the rotating valve ring **300** to accomplish the combustion cycle for each respective combustion cylinder of intake, compression, power, and exhaust will now be described with reference to FIG. **3B** and FIGS. **4A-4K**. Referring first to FIG. **3B**, combustion cylinder 1 is comprised of a cylindrical side wall **121** and a top wall **131**, which, in cooperation with piston **101** form a variable volume combustion chamber as described previously. In like

manner, combustion cylinder 2 is comprised of a cylindrical side wall **122** and a top wall **132**; combustion cylinder 3 is comprised of a cylindrical side wall **123** and a top wall **133**; combustion cylinder 4 is comprised of a cylindrical side wall **124** and a top wall **134**; and combustion cylinder 5 is comprised of a cylindrical side wall **125** and a top wall **135**.

Combustion cylinder 1 is further comprised of a port **141** that extends through the rotatable cylinder housing **110** from the top wall **131** of cylinder 1 to the external surface **117** of cylinder housing **110**. In the operation of engine **10**, the port **141** functions as a conduit for conveying fuel and air into combustion cylinder 1 during the intake stroke of the combustion cycle, and as a conduit for conveying ignition energy into combustion cylinder 1 during the ignition step of the combustion cycle, and as a conduit for conveying hot exhaust gases from combustion cylinder 1 during the exhaust stroke of the combustion cycle. Thus a single port is used for all three functions, in contrast to the dedicated spark plug, intake and exhaust valve ports provided in the cylinder heads of conventional internal combustion engines. In like manner, combustion cylinders 2-5 are further comprised of respective ports **142**, **143**, **144**, and **145** that extend through the rotatable cylinder housing **110** from the respective top walls **132**, **133**, **134**, and **135** to the external surface **117** of cylinder housing **110**.

This use of a single port for these three functions is made possible by the configuration and operation of the rotating valve ring **300**, and its synchronous rotation with the rotating cylinder assembly **100**. Referring again to FIG. **3B**, the rotating valve ring **300** is comprised of sets of intake, ignition, and exhaust ports disposed circumferentially around the perimeter of valve ring **300**. In the embodiment depicted in FIG. **3B**, there are eight port sets **301**, **302**, **303**, **304**, **305**, **306**, **307**, and **308**. Port set **301** is comprised of intake port **311**, ignition port **321**, and exhaust port **331**. In like manner, port sets **302-308** are comprised, respectively, of intake port **31x**, ignition port **32x**, and exhaust port **33x**, where x is between 2 and 8 inclusive.

During the combustion cycle, the rotating valve ring rotates synchronously with the rotating cylinder assembly **100**, but at a different rotational rate via the gearing described previously, so as to align an intake port with a combustion cylinder during the intake stroke, and to align an ignition port at the required time of ignition, and to align an exhaust port with a combustion cylinder during the exhaust stroke. This alignment of ports, which enables the combustion cycle for each cylinder of the engine **10** will now be described for combustion cylinder 1 only with reference to FIGS. **4A-4K**. It is to be understood that combustion cycles are occurring simultaneously for each of the combustion cylinders 2-5, with those combustion cycles offset by their relative angular positions around the rotating piston assembly **100**. The combustion cycle steps of intake stroke, compression stroke, ignition, power stroke, and exhaust stroke are now described.

Summary of Intake Stroke:

During the intake stroke of a piston from a distal end of a cylinder to the proximal end of the cylinder, the rotating valve ring positions an intake port for the respective combustion cylinder so that the combustion chamber of the cylinder is in communication with the intake plenum, thereby causing a gas contained in the intake plenum to flow into the combustion chamber. The intake stroke for cylinder 1 is depicted in FIGS. **4A-4C**. The gas may be a combustible gas that includes a combustible fuel.

Turning first to FIG. **4A**, the rotating cylinder assembly **100** has rotated approximately 10 degrees past the top dead

center (TDC) position shown in FIG. 3A, which depicts the end of an exhaust cycle and the beginning of an intake cycle for cylinder 1. In FIG. 4A, the intake stroke for cylinder 1 is beginning. Due to the offset of the axis of rotation 51 of the crankshaft 50 from the axis of rotation 109 of the rotating cylinder assembly 100, the piston 101 begins to move downwardly relative to the side and top walls of cylinder 1 as indicated by arrow 197. Although the rotating cylinder assembly 100 has rotated approximately 10 degrees past TDC, the rotating valve ring 300 has rotated to a slightly lesser extent, due to the geared relationship between then rotating valve ring 300 and the rotating cylinder assembly 100 described previously. Thus the intake valve port 311 is beginning to overlap the port 141 of cylinder 1. As a result of the downward motion of the piston 101, combustible mixture is caused to flow from the intake plenum 24 through the valve port 311, through the cylinder port 141, and into cylinder 1 as indicated by arrow 196.

Referring to FIG. 4B, the middle of the intake stroke is depicted. The rotating cylinder assembly 100 has rotated further, causing the piston 101 to continue its downward motion relative to the cylinder as indicated by arrow 197. The rotating valve ring 300 has also rotated further, but through a lesser angle than the rotating cylinder assembly 100 by virtue of the geared relationship with the rotating cylinder assembly 100. Intake valve 311 and cylinder port 141 are now fully aligned, and combustible mixture continues to flow through the intake plenum 24, the intake valve 311 and cylinder port 141 into cylinder 1 as indicated by arrow 196.

Referring to FIG. 4C, the end of the intake stroke is depicted. The rotating cylinder assembly 100 has rotated further, and piston 101 has nearly ceased its downward motion as indicated by arrow 197 relative to the cylinder. The rotating valve ring 300 has also rotated further, but again through a lesser angle than the rotating cylinder assembly 100. Cylinder port 141 has now nearly moved past intake valve 311. The flow of combustible mixture into cylinder 1 through the intake plenum 2 and the intake valve 311 as indicated by arrow 196 has nearly ceased. With a small further angular displacement of the rotating cylinder assembly 100 and rotating valve ring 300, the piston 101 ceases its downward motion, and the cylinder port 141 moves past the intake valve 311. The cylinder 101 is now sealed, and the compression stroke ensues.

SUMMARY OF COMPRESSION STROKE: During the compression stroke of the piston from the proximal end of the cylinder to the distal end of the cylinder, the rotating valve ring positions a first barrier wall that seals the top wall of the combustion cylinder, thereby causing compression of the gas in the combustion chamber as the piston moves from the proximal end of the cylinder to the distal end of the cylinder. The compression stroke for cylinder 1 is depicted in FIGS. 4D-4E.

Turning first to FIG. 4D, the beginning of the compression stroke is depicted. The rotating cylinder assembly 100 has rotated further, causing the piston 101 to begin its upward motion relative to the cylinder as indicated by arrow 195. The rotating valve ring 300 has also rotated further, but again through a lesser angle than the rotating cylinder assembly 100. A barrier wall 341 that is located in rotating valve ring 300 between intake valve 311 and ignition port 321 is now blocking cylinder port 141, thereby sealing cylinder 1. As the rotating cylinder assembly 100 continues to rotate, the piston 101 continues its upward motion, compressing the combustible gas contained therein.

Referring to FIG. 4E, the middle of the compression stroke is depicted. The rotating cylinder assembly 100 has rotated further, causing the piston 101 to continue its upward motion relative to the cylinder as indicated by arrow 195, further compressing the combustible mixture in cylinder 1. The rotating valve ring 300 continues to rotate through a lesser angle than the rotating cylinder assembly 100. The barrier wall 341 continues to block cylinder port 141. With a further angular displacement of the rotating cylinder assembly 100 and rotating valve ring 300, the upward motion of piston 101 slows as cylinder 1 approaches top dead center. Ignition of the combustible gas in cylinder 1 then ensues.

Summary of Ignition:

At or near the end of the compression stroke of the piston, the rotating valve ring positions an ignition energy port in communication with the combustion chamber and an ignition energy source, thereby delivering ignition energy to the gas and igniting the gas. The ignition step for cylinder 1 is depicted in FIG. 4F.

Referring to FIG. 4F, the rotating valve ring 300 has rotated such that ignition energy port 321 is aligned with cylinder port 141, thus placing an ignition energy source (not shown) disposed in ignition source port 28 in communication with cylinder 1. Ignition energy is delivered from the ignition energy source through ignition energy port 321 of rotating valve ring 300 and through cylinder port 141 as indicated by arrow 194, thereby causing ignition of the combustible gas contained in cylinder 1. It is noted that the engine 10 may be operated with only a single ignition energy source and ignition source port 28. Multiple ignition energy sources are not needed for operation of the engine 10.

In certain embodiments, the ignition energy source may be a spark plug (not shown) that is fitted in ignition source port 28. Energizing of the spark plug is controlled such that the sparking of the plug is timed to occur at the time that ignition energy port 321 is aligned with cylinder port 141. The sparking element of the spark plug may extend down within ignition energy port 321 to the point where it is nearly in contact with surface 117 of cylinder housing 110. The sparking element may be configured to fire a high energy electrical discharge down through cylinder port 141 into cylinder 1.

It is noted that in the embodiment of the engine 10 depicted in FIGS. 1-4K, the ignition source port 28 is located such that ignition energy is delivered at approximately top dead center of the cylinder rotation. However, it is well known that spark advance is used to improve efficiency of internal combustion engines. Thus, the ignition source port 28 may be located in the counterclockwise direction on the engine block 20, so that ignition energy is delivered to the cylinders before they reach top dead center. The location of ignition energy port 321 may also be adjusted accordingly so that the proper alignment with ignition source port 28 and cylinder port 141 occurs at the desired ignition time. Additionally, the ignition source port 28, ignition energy port 321, and/or cylinder port 141 may have their respective shapes altered, possibly to have oblong shapes, thereby resulting in a longer duration of port alignment so that ignition energy timing may be made more adjustable. In an alternative embodiment, the ignition source port may be provided with a sliding mechanism and seals so that its position is circumferentially adjustable. In that manner, ignition timing may be advanced or retarded as needed to match engine operating conditions.

It is also noted that in the previous description of the intake stroke, compression stroke, and ignition step, these

operations have been described in the context of there being an external source of combustible gas or combustible liquid fuel droplets, which is delivered through the intake plenum 24 of the engine block 20. However, it is not necessary that the combustible fuel be provided from an external source and delivered to plenum 24. In an alternative embodiment (not shown), a fuel injector (or multiple injectors) may be provided for delivery of combustible fuel. This injector may be fitted to the engine block in a region where it is in communication with the plenum 24, so that it injects combustible gas or atomized liquid directly into plenum 24 during the intake stroke of any cylinder 1-5. The fuel injector(s) may be oriented so that the injection spray or gas discharge is directed at the intake port of the rotating valve ring 300 as it rotates past the injector(s).

It is also noted that in the above descriptions of the intake stroke, compression stroke, and ignition step, these operations have been described in the context of the combustible mixture being formed in advance of being taken into a combustion cylinder, i.e. the combustible mixture is formed in a manner similar to a conventional spark ignition gasoline or compressed natural gas (CNG) engine.

However, it is not necessary that the combustible mixture be formed in advance of ignition thereof. In an alternative embodiment (not shown), the engine 10 may be operated as a diesel engine. In such an embodiment, a diesel fuel injector may be provided for injection of diesel fuel into the cylinders 1-5 at the desired ignition time. In certain embodiments, the diesel fuel injector may be fitted to the ignition source port 28 of the engine block 20, so that it injects diesel fuel directly into a cylinder, such as into cylinder 1 through ignition energy port 321 and cylinder port 141. The fuel then ignites as in a conventional diesel engine. In that regard, the ignition energy source that causes ignition of the combustible gas in the cylinder is the diesel fuel itself.

With the ignition of the combustible gas in the cylinder having occurred, the power stroke of engine 10 now proceeds.

Summary of Power Stroke:

During the power stroke of the piston from a distal end of the cylinder to the proximal end of the cylinder, the combustible gas burns while the rotating valve ring positions a second barrier wall that seals the top wall of the combustion cylinder, thereby causing an increase in pressure within the combustion chamber, thereby applying a force on the piston and the connecting rod in the proximal direction, and thereby applying a torque on the crankshaft to cause crankshaft rotation. The power stroke for cylinder 1 is depicted in FIGS. 4G-4H.

Turning first to FIG. 4G, the middle of the power stroke is depicted. The rotating cylinder assembly 100 has rotated further, and the high pressure of the hot combustion gas within cylinder 1 is forcing the piston 101 downwardly relative to the cylinder as indicated by arrow 193. Connecting rod 111 transmits the force to the crankshaft 50, thus applying a torque thereto and causing crankshaft rotation as indicated by arrow 59. The rotating valve ring 300 has also rotated further, but again through a lesser angle than the rotating cylinder assembly 100. A barrier wall 342 that is located in rotating valve ring 300 between and ignition port 321 and exhaust valve 331 is now blocking cylinder port 141, thereby sealing cylinder 1. As the rotating cylinder assembly 100 continues to rotate, the piston 101 continues its forceful downward motion, as the hot exhaust gas contained therein expands.

It is noted that the location of the connections of the rods 111-115 to the crankshaft 50 may be different than what is

depicted in the drawings. For example, each of the rods 111-115 may be connected to the flange 52 of the crankshaft at a location that is further around the crankshaft in the clockwise direction in FIG. 4G. Additionally, the flange 52 may be larger than depicted, so that the "lever arm" action of the rods 111-115 on the crankshaft 50 is increased. In that manner, optimum torque of the rods on the crankshaft is obtained.

Additionally, the Applicant has performed a vector analysis of forces that occur during operation of the internal combustion engine 10. Without wishing to be bound to any particular theory, the Applicant believes that during operation of the engine 10, the reciprocating action of the pistons 101-105 within their respective cylinders provides an additional torque on the rotating cylinder assembly 100, which in turn is applied to the crankshaft 50.

Referring to FIG. 4H, the end of the compression stroke is depicted. The rotating cylinder assembly 100 has rotated further, and piston 101 has nearly ceased its downward motion as indicated by arrow 193 relative to the cylinder. The rotating valve ring 300 has also rotated further, but again through a lesser angle than the rotating cylinder assembly 100. Cylinder port 141 remains blocked by barrier wall 342. With a small further angular displacement of the rotating cylinder assembly 100 and rotating valve ring 300, the piston 101 ceases its downward motion, and the cylinder port 141 approaches the exhaust valve 331. The exhaust stroke ensues.

Summary of Exhaust Stroke:

During the exhaust stroke of the piston from the proximal end of the cylinder to the distal end of the cylinder, the rotating valve ring positions an exhaust port for the respective combustion cylinder so that the combustion chamber of the cylinder is in communication with the exhaust plenum, thereby causing combustion gas contained in the combustion chamber to flow into the exhaust plenum and out of the engine. The exhaust stroke for cylinder 1 is depicted in FIGS. 4I-4K.

Turning first to FIG. 4I, the beginning of the exhaust stroke is depicted. The rotating cylinder assembly 100 has rotated further, causing the piston 101 to begin its upward motion relative to the cylinder as indicated by arrow 192. The rotating valve ring 300 has also rotated further, but again through a lesser angle than the rotating cylinder assembly 100. Thus the exhaust valve port 331 is beginning to overlap the port 141 of cylinder 1. As a result of the upward motion of the piston 101, hot exhaust gas is caused to flow from cylinder 1 through the cylinder port 141, through the exhaust valve port 331, through the exhaust plenum 24 and out of the engine block 20 as indicated by arrow 191.

Referring to FIG. 4J, the middle of the exhaust stroke is depicted. The rotating cylinder assembly 100 has rotated further, causing the piston 101 to continue its upward motion relative to the cylinder as indicated by arrow 192. The rotating valve ring 300 has also rotated further, but again through a lesser angle than the rotating cylinder assembly 100. Exhaust valve 331 and cylinder port 141 are now fully aligned, and the hot exhaust gas continues to flow from cylinder 1 through the cylinder port 141, through the valve port 311, through the intake plenum 24 and out of the engine block 20 as indicated by arrow 191.

Referring to FIG. 4K, the end of the exhaust stroke is depicted. The rotating cylinder assembly 100 has rotated further, and piston 101 has nearly ceased its upward motion as indicated by arrow 192 relative to the cylinder as cylinder 1 approaches top dead center. The rotating valve ring 300

has also rotated further, but again through a lesser angle than the rotating cylinder assembly 100. Cylinder port 141 has now nearly moved past exhaust valve 331. The flow of exhaust gas from cylinder 1 as indicated by arrow 191 has nearly ceased.

With a small further angular displacement of the rotating cylinder assembly 100 and rotating valve ring 300, the piston 101 ceases its upward motion at top dead center, and is in the position as shown in FIG. 3A. The entire combustion cycle of intake, compression, ignition, power, and exhaust is then repeated. It is noted that on the combustion cycle described above, the port set 301 comprising of intake port 311, ignition port 321, and exhaust port 331 were used to perform the functions of intake, ignition, and exhaust. On the next cycle, the port set 302 comprising of intake port 312, ignition port 322, and exhaust port 332 will be used to perform the functions of intake, ignition, and exhaust. On subsequent combustion cycles, the port sets 303, 304, 305, 306, 307, and 308 (see also FIG. 3B) will be used for intake, ignition, and exhaust. Then the entire cycle will continue to repeat using port sets 301-308 in sequence.

In the embodiment of the engine 10 depicted in FIGS. 2E-4K, the rotating piston assembly 100 is comprised of five cylinders 1-5, and the rotating valve ring is comprised of eight port sets 301-308. Thus, with the engine 10 operating as a four cycle engine, the combustion cycle requires two rotations of the rotating cylinder assembly 100. Concurrently, the rotating valve ring 300 rotates two rotations minus the sector angle occupied by a single set of ports. With there being eight port sets 301-308, a single port set occupies a sector of 45 degrees, or one eighth of the circumference of the rotating valve ring. Hence, during a combustion cycle, while the rotating cylinder assembly 100 rotates two times, the rotating valve ring 300 rotates 1 $\frac{7}{8}$ times. The rotational ratio of the rotating cylinder assembly 100 to the rotating valve ring 300 is thus 16/8:15/8, or 16:15. The gearing between the rotating cylinder assembly 100 and the rotating valve ring 300 as described previously herein provides this rotational ratio.

It is to be understood that other configurations of the engine 10 are contemplated. Firstly, the engine 10 may be comprised of more or less than five cylinders 1-5. Secondly, other port configurations for the rotating valve ring 300 are possible. The rotating valve ring 300 may have more or fewer port sets, so long as the proper gearing is provided so as to align an intake port with a cylinder port during the intake stroke, and to align an ignition port with the cylinder port during delivery of ignition energy, and to align an exhaust port with the cylinder port during the exhaust stroke. The gearing between the rotating cylinder assembly 100 and the rotating valve ring 300 as described previously herein is thus adjusted accordingly to provide the required rotational ratio to accomplish the desired alignment of the ports during intake, ignition, and exhaust.

Additionally, it is not required that the rotating cylinder assembly 100 rotates at a higher speed than the rotating valve ring 300. In other embodiments, the rotating cylinder assembly 100 may rotate at a lower speed than the rotating valve ring 300. In such a configuration, the order of porting of the rotating valve ring simply needs to be reversed, i.e., the porting order is exhaust-ignition-intake, rather than intake-ignition-exhaust as shown in FIG. 3B. In that manner, the desired port alignments during intake, ignition, and exhaust is provided. Again, the gearing between the rotating cylinder assembly 100 and the rotating valve ring 300 as described previously herein is adjusted accordingly to pro-

vide the required rotational ratio to accomplish the desired alignment of the ports during intake, ignition, and exhaust.

The respective materials of construction of the engine block 20, the cylinder housing 110, the pistons 101-105, the piston rods 111-115, the crankshaft 50, and the rotating valve ring 300 may be the same as used for analogous parts in conventional internal combustion engines. Such materials may include but are not limited to cast iron, aluminum alloys, steel alloys, and ceramics, with the operative requirements for any particular material including sufficient structural strength, resistance to heat generated by combustion of fuel within the cylinders, and resistance to chemical degradation by the fuel and by the hot exhaust gases.

In certain embodiments, the number of sets of valve port sets S may be defined by the relationship:

$$S=(1.5 \times C)+0.5$$

where C is equal to any odd number of combustion cylinders.

Additionally, the ratio R of the number of rotations of the rotating cylinder assembly 100 to the number of rotations of the rotating valve ring 300 may be defined by the relationship:

$$R=1+1/(3C).$$

It can be seen that for the exemplary internal combustion engine depicted in the drawings and described herein, the above equations apply. The exemplary engine has five cylinders. Thus S=16/15, and R=8 port sets as described previously.

The rotating cylinder assembly 100 and rotating valve ring 300 may be provided with seals to contain the combustible intake mixture and the combustion gases within the desired locations of the engine 10 during the combustion cycle. Referring again to FIG. 2E, each of the cylinder ports are provided with a seal or seals to prevent gas leakage between the rotating cylinder housing 110 and the inner surface 350 of the rotating valve ring 300. For example, cylinder port 141 may be provided with seals 151 and 152 that are disposed in machined grooves in the external surface 117 of the rotating cylinder housing 110. In alternative embodiment (not shown), an O-ring seal that surrounds cylinder port 141 may be provided. In like manner, the various valve ports of the rotating valve ring 300 may also be provided with seals 351 fitted to grooves formed in the outer surface 352 thereof, or with seals that surround each of the respective ports in the rotating valve ring 300.

The various seals are made of materials such as, e.g., a fluoropolymer or a ceramic, that are suitably resistant to heat and chemical degradation by the combustion fuel and the hot exhaust gases.

It is, therefore, apparent that there has been provided, in accordance with the present invention, an internal combustion engine. Having thus described the basic concept of the invention, it will be rather apparent to those skilled in the art that the foregoing detailed disclosure is intended to be presented by way of example only, and is not limiting. Various alterations, improvements, and modifications will occur to those skilled in the art, though not expressly stated herein. These alterations, improvements, and modifications are intended to be suggested hereby, and are within the spirit and scope of the invention. Additionally, the recited order of processing elements or sequences, or the use of numbers, letters, or other designations therefore, is not intended to limit the claimed processes to any order except as may be specified in the claims.

15

I claim:

1. An apparatus comprising:

- a) a block comprised of a main cavity, an intake plenum, and an exhaust plenum;
- b) a crankshaft supported within the main cavity of the block and having a crankshaft axis of rotation;
- c) a rotating piston assembly contained within the main cavity of the block and comprised of a rotatable cylinder housing having a housing axis of rotation and comprised of a plurality of pistons contained in cylinders, the cylinder housing axis of rotation parallel to and offset from the crankshaft axis of rotation, each of the plurality of cylinders comprising a cylindrical side wall and a top wall formed in the cylinder housing, and each piston operatively connected by a piston rod to the crankshaft and reciprocable along the central axis of the cylindrical side wall, wherein for each of the plurality of pistons in cylinders, the piston and the cylindrical side wall and top wall of the cylinder form a variable volume chamber; and
- d) a rotating valve ring contained within the block and surrounding the rotating piston assembly, the rotating valve ring comprised of valve port sets, each valve port set comprising intake ports and exhaust ports communicable with each of the plurality of cylinders;

wherein:

the rotating piston assembly and the rotating valve ring are operatively coupled to the crankshaft such that the rotating piston assembly and the rotating valve ring rotate synchronously with rotation of the crankshaft; rotation of the piston assembly around the rotatable cylinder housing axis of rotation causes the distance from the crankshaft to the cylindrical side wall of each combustion cylinder to vary periodically, thereby causing each piston to reciprocate within its cylindrical side wall in repeated intake and exhaust strokes;

for each respective cylinder, during the intake stroke of the piston contained therein from a distal end of the cylinder to the proximal end of the cylinder, the rotating valve ring positions an intake port for the respective cylinder so that the chamber of the cylinder is in communication with the intake plenum, thereby causing a gas contained in the intake plenum to flow into the chamber;

and during the exhaust stroke of the piston from the proximal end of the cylinder to the distal end of the cylinder, the rotating valve ring positions an exhaust port for the respective cylinder so that the chamber of the cylinder is in communication with the exhaust plenum, thereby causing gas contained in the chamber to flow into the exhaust plenum.

2. The apparatus of claim 1, wherein the number of cylinders is an odd number.

3. The apparatus of claim 2, wherein the number of valve ports is S, and is defined by the relationship $S=(1.5 \times C)+0.5$, where C is the number of cylinders.

4. The apparatus of claim 2, wherein in the synchronous rotation of the rotating piston assembly and the rotating valve ring, the ratio of the number of rotations of the rotating piston assembly to the number of rotations of the rotating valve ring is R and is defined by the relationship $R=1+1/(3C)$, where C is the number of cylinders.

5. The apparatus of claim 1, wherein the rotational speed of the rotating valve ring is greater than the rotating speed of the rotating piston assembly.

16

6. The apparatus of claim 1, wherein the rotational speed of the rotating valve ring is less than the rotating speed of the rotating piston assembly.

7. The apparatus of claim 1, wherein the number of cylinders is an even number.

8. The apparatus of claim 1, further comprising:

a crankshaft gear engaged with the crankshaft and rotatable with the crankshaft around the crankshaft axis of rotation and comprising outer crankshaft gear teeth;

a valve ring annular gear joined to the rotating valve ring and rotatable around the cylinder housing axis of rotation and comprising valve ring inner gear teeth;

a piston annular gear joined to the rotating piston assembly and rotatable around the cylinder housing axis of rotation and comprising piston assembly inner gear teeth;

a double annular gear set rotatable around the cylinder housing axis of rotation and comprising a first inner gear having first inner gear teeth engaged with the outer crankshaft gear teeth of the crankshaft gear, and a second inner gear having second inner gear teeth; and

a main gear set disposed upon the crankshaft and rotatable with respect to the crankshaft around the crankshaft axis of rotation, and comprising a front gear having outer gear teeth engaged with the second inner gear teeth of second inner gear, a middle gear having outer gear teeth engaged with the valve ring inner gear teeth of the inner valve ring annular gear, and a rear gear having outer gear teeth engaged with the piston assembly inner gear teeth of the piston annular gear.

9. The apparatus of claim 8, wherein:

each of the valve port sets of the rotating valve ring includes an ignition energy port communicable with each of the plurality of cylinders;

the rotation of the piston assembly around the rotatable cylinder housing axis of rotation further causes each piston to reciprocate within its cylindrical side wall in repeated intake, compression, power, and exhaust strokes;

for each respective cylinder, during the compression stroke of the piston from the proximal end of the cylinder to the distal end of the cylinder, the rotating valve ring positions a first barrier wall that seals the top wall of the cylinder, thereby causing compression of the gas in the chamber as the piston moves from the proximal end of the cylinder to the distal end of the cylinder;

and at substantially the end of the compression stroke of the piston, the rotating valve ring positions an ignition energy port in communication with the chamber and an ignition energy source, thereby delivering ignition energy to the gas, thereby causing the gas in the chamber to ignite;

and during the power stroke of the piston from a distal end of the cylinder to the proximal end of the cylinder, the gas combusts while the rotating valve ring positions a second barrier wall that seals the top wall of the cylinder, thereby causing an increase in pressure within the chamber, thereby applying a force on the piston and the connecting rod in the proximal direction, and thereby applying a torque on the crankshaft to cause crankshaft rotation.

10. The apparatus of claim 9, wherein the number of cylinders is an odd number.

11. The apparatus of claim 10, wherein the number of valve ports is S, and is defined by the relationship $S=(1.5 \times C)+0.5$, where C is the number of cylinders.

12. The apparatus of claim 10, wherein in the synchronous rotation of the rotating piston assembly and the rotating valve ring, the ratio of the number of rotations of the rotating piston assembly to the number of rotations of the rotating valve ring is R and is defined by the relationship $R=1+1/5(3C)$, where C is the number of cylinders.

13. The apparatus of claim 9, wherein the block includes a single ignition source port that is communicable with each of the ignition energy ports of the valve port sets.

14. The apparatus of claim 9, wherein during the intake stroke, the gas contained in the intake plenum that is caused to flow into the combustion chamber is a combustible gas.

15. The apparatus of claim 9, wherein the number of cylinders is an even number.

* * * * *